



# BASIC LAGOON WASTEWATER TREATMENT MANUAL



# **BASIC LAGOON WASTEWATER TREATMENT MANUAL**

Prepared for the

***Montana Department of Environmental Quality  
and  
Montana Environmental Training Center***

Based on the Lagoon Training Manual prepared by

***Ken Johnston, Water Services Co.  
June 1992***

Updated and Edited by

***Montana Department of Environmental Quality in 2020  
Pete Boettcher and Josh Viall***

Lagoon pictured on front cover is the Belt Facultative Lagoon.

# BASIC LAGOON WASTEWATER TREATMENT MANUAL

April 2020

## TABLE OF CONTENTS

---

<b><u>Subject</u></b>	<b><u>Page Number</u></b>
<b>INTRODUCTION</b>	
<b>CHAPTER 1: WHO HAS RESPONSIBILITY?</b>	
Who Has Responsibility?	7
<b>CHAPTER 2: WHAT IS WASTEWATER?</b>	
What is Wastewater?	10
Wastewater Analysis	14
<b>CHAPTER 3: HEADWORKS</b>	
Headworks	17
Types of Lagoons	19
Biology of Wastewater Lagoons	21
<b>CHAPTER 4: FACULTATIVE LAGOONS</b>	
Facultative Lagoons	24
Other Operational Considerations	25
General Operation and Maintenance	29
<b>CHAPTER 5: AERATED LAGOONS</b>	
Aerated Lagoon	33
Aeration Systems	35
Operation and Maintenance	39
<b>CHAPTER 6: DISINFECTION</b>	
Disinfection	42
Methods to Disinfect Wastewater	43
<b>CHAPTER 7: CONVEYANCE SYSTEMS</b>	
Conveyance Systems	48
Lift Stations, Pumps and Motors	49
Motors and Electricity	52
<b>CHAPTER 8: SAFETY</b>	
Safety	54

<b>CHAPTER 9: SAMPLING</b>	
Sampling	58
<b>CHAPTER 10: FLOW MEASUREMENT</b>	
Flow Measurement	61
<b>CHAPTER 11: LAWS, REGULATIONS, PERMITS</b>	
Laws, Regulations, Permits	65
Biosolids Disposal	67
Industrial Pretreatment	68
Operator Certification	68
<b>CHAPTER 12: MATH</b>	
Math and Calculations	71
Math Formula Sheet	79
<b>APPENDICES</b>	
Study Material for Wastewater Exams	
Wastewater Terms	
Example of Discharge Monitoring Report	
Log Sheets	
Trend Charts	

# BASIC WASTEWATER TREATMENT TRAINING MANUAL

## INTRODUCTION

There is a story that many years ago, a community, having no stream to discharge their sewage waste, ran the raw sewage directly into a nearby "pothole" – a glaciated pond common to the region. Strangely, the pothole did not exhibit the odors and vile conditions that they expected from a raw sewage dump. There also is evidence that some variations of stabilization ponds have been used for more than 3,000 years. One of the earliest actual installations of a lagoon for discharging raw sewage may have been in San Antonio, Texas in 1901.

The concept of the sewage lagoon, or stabilization pond, was developed and extended to thousands of towns and cities around the world. The lagoon has been adapted to a wide variety of treatment systems and has undergone improvements and changes through the years. The lagoon is well suited as a treatment system for small communities such as those found throughout Montana. It is relatively inexpensive to construct, low in maintenance costs, and if operated wisely, will produce a good quality effluent.

The simplicity of the lagoon system sometimes leads to neglect. The result of neglect, poor maintenance, or inadequate operation can produce a poor-quality effluent and perhaps a smelly local problem. Further, poorly operated or maintained lagoons can cause serious contamination of groundwater or surface water. It may not be easily noticed, but leakage through a damaged liner or leaking pipe can do irreparable harm to nearby water resources that may be a source of someone's drinking water.

Montana is blessed with some of the finest quality waters in the nation. Wastewater treatment facilities have been built at great public expense. It is very important that each of us do our best to maintain or improve the waters we use and enjoy. The treatment plant operators are on the front line and it is their duty to make sure that water leaving their wastewater system is of the best possible quality. The Montana Operator Code of Ethics provides a good general description of the important aspects of the operator's job, described as follows:

*Using my best judgment and operating skills, I will always work to protect public health, to ensure good service, to protect public property and the environment by applying my skills in operating water and wastewater system equipment, by properly and accurately completing required records, following and complying with state and federal rules and regulations, continuing my education in my field, and working with management to establish distinct and safe operating policies for the public utilities for which I am entrusted.*

This manual is designed to be a resource for operators in Montana working in lagoon wastewater treatment facilities. It provides information on the basics of wastewater

treatment focused on lagoon systems. A good reference for the Lagoon Operator is the manual written by Steve Harris "*Lagoon Troubleshooting*" available from USA Blue Book at: <https://www.usabluebook.com/search?searchterm=Lagoon+Troubleshooting>

More complex subjects such as operation of mechanical treatment processes are not covered in this document. It is the operator's responsibility to find the appropriate reference materials and spend the necessary time to prepare for the exam. Other references for smaller systems that may be helpful to operators or potential operators include:

*"Wastewater Treatment Fundamentals Volume I Liquid Treatment,"* prepared by the Water Environment Federation (WEF) and Association of Boards of Certification (ABC).

There is a second manual in the works on Solids Handling and we would recommend obtaining a copy when it is available at: <https://www.wef.org/resources/publications/books/wastewater-treatment-fundamentals/>

*"Operation of Wastewater Treatment Plants, Volumes I & II,"* California State University (Ken Kerri Manuals)

*"Small Wastewater System O&M, Volumes I,"* California State University (Ken Kerri Manuals)

*"Wastewater Math, The Basics,"* by Skeet Arasmith, ACRP Publications

In this manual, the types of lagoons and the biological processes that make them work are considered. The design and operation of facultative lagoons and aerated lagoons are reviewed with helpful advice provided. A section on safety will remind the operator of safe (and unsafe) practices. Mathematics of lagoon operation is included. A chapter on wastewater conveyance systems covering lift stations, piping, pumps and electricity has also been included. Of special importance is a chapter covering the regulations, laws, permits, and reports that apply to the operation of wastewater treatment systems and the discharge of properly treated wastewater.

# CHAPTER 1

## I. WHO HAS THE RESPONSIBILITY?

There are usually three responsible parties in any wastewater treatment facility including: (1) The Owner, (2) The Operator, and (3) The Regulatory Agencies.

The OWNER has the ultimate responsibility for the system. The Owner may be the company management, if it's a private business, the city council, sewage district board, school board, or similar commission. In a publicly owned system, the OWNER represents the ratepayers who ultimately are responsible for the financial support of the wastewater system.

The **OWNER** must provide:

- **Physical Facilities**

The owner will make decisions on selection of engineering firms and construction contractors needed to design and construct treatment facilities. Note: Any modifications must be designed by a professional engineer licensed in the State of Montana.

- **Financing**

The owners are responsible to provide the money required to maintain and operate the facilities. The owner will budget and oversee the finances.

- **Government Permits to Build and Operate the Plant**

Construction and discharge permits are obtained by and are in the name of the owner. Note: Plant specifications for all wastewater treatment modifications must be approved by the Department of Environmental Quality (75-6-102 Montana Codes Annotated).

- **General Policy for Maintenance and Operation**

Policy decisions and directions regarding support, operation and maintenance of the wastewater system are be made by the owner.

- **Operators**

The owner will hire the necessary personnel to operate and maintain the facility. The owner must see that all personnel receive training and are certified for the position they hold.

The **operator** is responsible to the owner for:

- **Certification**

The operator must apply for, and pass, certification tests, at the appropriate classification level. as the responsible person in charge. To maintain certification, the operator must obtain continuing education through attendance of classes or other forms of training. The operator must also maintain his or her license through payment of the annual renewal fee.

- **Facilities Operation**

The operator is responsible for all operational work at the treatment facility, which might include process control testing, compliance monitoring, supervision, scheduling, trend charting, general record keeping, and many other aspects required for good plant operation.

- **Record Keeping**

The operator must be familiar with the discharge permit requirements and work to ensure that the treatment system complies with applicable state and federal laws. He or she must keep proper records of operation and must know how to interpret the records.

- **Sampling and Testing**

The operator must obtain good representative samples for laboratory testing. The operator should understand the significance of the results of the testing and utilize the results in operation of the plant.

- **Reporting**

The operator must prepare and submit timely reports.

- **Maintenance of the Plant**

The buildings, equipment, treatment structures and grounds must be kept in good condition, with repairs completed as needed.

- **Continued Training**

The operator must continue to keep informed on subjects relating to wastewater treatment and water quality.



- Provide **Information to the OWNER**

The operator should prepare an annual budget for OWNER approval, attend meetings, and report on matters concerning wastewater treatment.

The **REGULATORY AGENCIES** are responsible for seeing that wastewater facilities are constructed and operated in accordance with the laws and regulations protecting water quality in our state and our nation. Similar to the owner, the regulatory agencies represent the public, including local ratepayers, taxpayers, and the public in general.

- The Montana Department of Environmental Quality (DEQ) is the state agency charged with enforcing water quality based regulatory requirements in Montana, including administration of the Montana Water Quality Act.

All questions and matters of regulation and certification should be directed to the following DEQ programs:

Discharge Permits: Water Protection Bureau  
Operator Certification: Operator Certification Program  
Plans and Specifications: Engineering Bureau  
Funding: Water, Wastewater and Solid Waste Action Coordinating Team  
(WASACT): <http://dnrc.mt.gov/divisions/cardd/wasact>

- The US Environmental Protection Agency (EPA) administers the Clean Water Act and enforces its pollution prevention provisions, and related federal laws and rules as authorized by Congress. Many of the legal requirements of the Clean Water Act are delegated by EPA to the states for administration.

Regulatory requirements are discussed in more detail in Chapter 11 of this manual.

## CHAPTER 2

### I. WHAT IS WASTEWATER?

Most of us think of wastewater in terms of our domestic usage. The dishwater that we dump down the drain, our shower water, and the stuff that goes down the toilet when we flush it. An experienced sewage collection system or treatment plant operator will tell you that it can be highly variable in both quantity and characteristics. Wastewater can be made up of primarily *domestic waste* that comes from the home, and in small communities this is the predominant characteristic. It also can carry industrial and commercial wastes—such as water from a car wash that has little organic material, but a lot of dirt and grit, or the fast food restaurant that releases fats and grease. Wastewater often picks up ground water through leaks in the collection system or stormwater discharged through roof and street drains. There may be a dairy or food processing operation that periodically releases strong waste material. Toxic compounds may be illegally discharged into a sewer system. Each source adds differing wastes in quality and quantity. A summary of the general characteristics of wastewater might include:

1. Domestic sewage that contains human and animal wastes, and general household wastewater.
2. Industrial waste that originates from manufacturing or processing operations.
3. Storm water and surface runoff is water originating from rain or snow on streets, roof drains, or sump pumps and is sometimes called inflow.
4. Ground water infiltration can happen when pipe joints and cracks allow leakage or *infiltration* into the pipe, especially if the ground water table is high.
5. Illegal discharges carry a wide variety of pollutants into surface and ground waters to a sewer system. These may be intentionally or unknowingly discharged. The consequences of illegal discharge can be severe. Proper disposal of wastes such as chemicals, oils, and solid wastes are necessary to prevent serious water pollution. Sewer Use Ordinances are local regulations that should be adopted by communities to control the discharge of undesirable wastes.

The material carried in the wastewater is what concerns the wastewater treatment plant operator. These materials can be either *dissolved, suspended, or settleable solids*. If a solid is held on a laboratory filter, it is considered a suspended solid. If it passes through the lab filter, it is a dissolved solid. Some solids coming down the sewer are heavy enough that they settle out easily in quiet water. These are called *settleable solids*.

The treatment of wastewater is a process for converting undesirable dissolved, suspended, and settleable solids into stable and acceptable forms. Typical domestic wastewater consists of less than 0.1 percent solids carried in the water. Many of these

impurities can do serious harm to the receiving water, if discharged in large quantity relative to the flow in the stream.

There are two broad classifications of these wastewater substances: organic and inorganic. Organic materials are of plant or animal origin. Inorganic materials are of mineral origin without carbon compounds. In wastewater lagoon treatment systems, most inorganic materials are easily handled if the volume in the system has allowed for the accumulation of solids. Grit and heavier solids settle readily when they enter a lagoon cell and the velocity of the water drops off.

The first, or primary cell in a lagoon system that has been in operation for many years will have a pronounced buildup of solids around the influent location. This is the result of heavier settleable and mostly inorganic solids such as grit particles dropping out of suspension rather quickly. The organic materials in wastewater are much more varied, more complex and more difficult to handle since they don't settle readily and are usually dissolved. An overall objective of a wastewater treatment system is to convert these dissolved materials into solids that can be readily removed from the flow stream. It is the organic treatment that will be the subject of most of the discussion in this manual.

Recently constructed sewage lagoons are designed with capacity on the bottom of the cell to hold solids. Solids in lagoon systems will eventually require periodic removal to ensure that adequate treatment capacity is available for the biological treatment of organic compounds. Many Montana lagoons undergoing upgrades must have sludge removed as part of the construction project. The regulatory requirements for disposal of the sludge is discussed in Chapter 11 of this manual. The removed solids will require additional stabilization before they can be landfilled, or land applied.

## **FLOW AND LOAD VARIATIONS**

The composition and the quantity of wastewater varies constantly all day and all night. As you might expect, normal community activities cause dramatic water drops during the night, and by 5:00 or 6:00 a.m. has reached the low point of the day. As people arise, shower, wash, cook, and start the day's activities wastewater flow rapidly increases, reaching a maximum in the late morning. Flow continues strong during the day and begins to taper off during the evening hours.

This diurnal, or daily flow, is also accompanied by a corresponding shift in the strength of the sewage, so that the system receives both higher volume and higher strength loading during the day with weaker and lower flow at night. The two graphs shown below illustrate how the flow and waste strength may vary over a 24-hour period. The lines showing the average flow and BOD<sub>5</sub> (biochemical oxygen demand) loading are the average of the daily peaks and valleys for these two parameters. Average daily flow (ADF) is often used to evaluate the capacity of a wastewater treatment system.

Many communities experience variable flows on a seasonal basis. Older collection systems with leaky pipes may pick up groundwater, rainwater, or snowmelt during the

wetter periods of the year, causing a significant increase in the wastewater flow volume. Communities that experience an influx of tourists also see major seasonal changes in flow volumes.

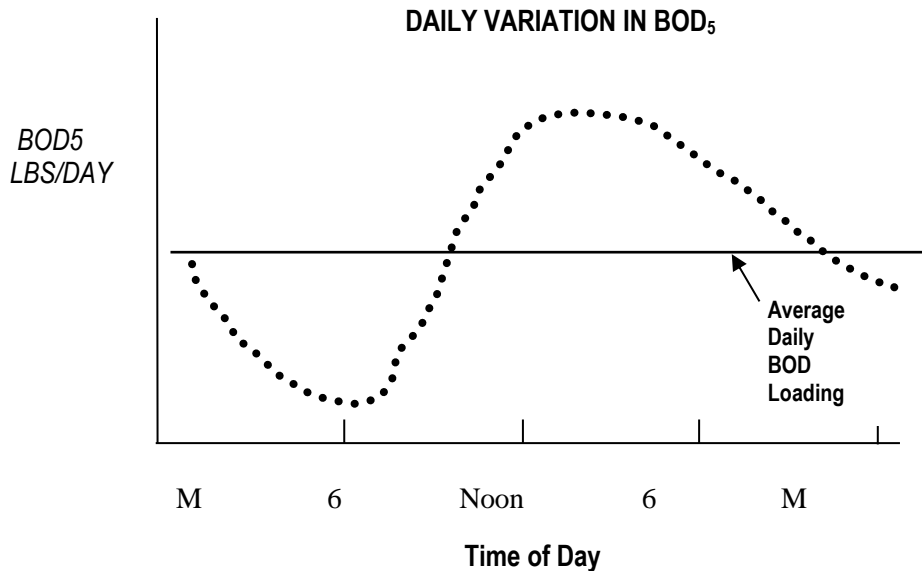
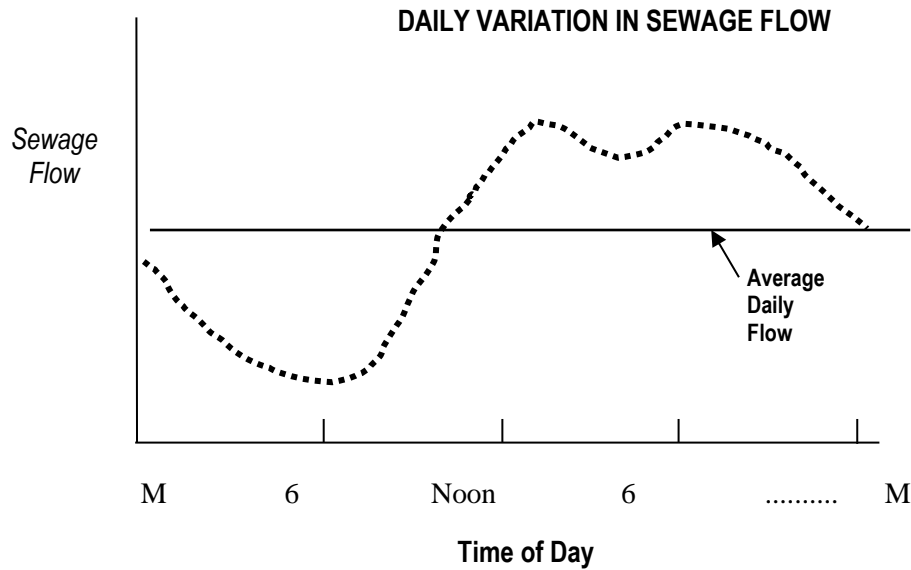

Treatment facilities must be designed to handle these high flow events to produce an acceptable level of treatment prior to discharge. Lagoons with large capacity will even out this flow before discharge.

Fresh domestic sewage is typically gray colored water, not unlike the appearance of dirty dishwater. It has a kind of musty, but not highly objectionable odor. If sewage is not fresh or has been in the collection system for a long time, it can turn *septic*. Septic sewage is black with a strong foul odor and is devoid of oxygen. It is important to avoid

septic conditions in a wastewater collection or treatment system due to the nuisance odor conditions that can result.

## TYPICAL CHARACTERISTICS

### MEDIUM STRENGTH DOMESTIC SEWAGE

Total Solids	600 mg/L*
Total Dissolved Solids	400 mg/L
Total Suspended Solids	200 mg/L

### APPROXIMATE COMPOSITION

	<u>Organic</u>	<u>Inorganic</u>
Total Dissolved Solids	40%	60%
Total Suspended Solids	70%	30%

\*Milligrams per liter

## OTHER IMPORTANT CHARACTERISTICS

pH is the measure of how acidic or how basic a solution is and is an important measurement in wastewater treatment. The pH scale ranges from 1 to 14 with 7 being exactly neutral. Fresh domestic sewage is approximately neutral, but if it is slow in reaching the treatment facility, the pH may become slightly acid with a pH below 7.

<u>1</u>	<u>7</u>	<u>14</u>
acid	neutral	basic

BOD<sub>5</sub>, or biochemical oxygen demand, is a measure of the strength of sewage. It is a measure of the amount of oxygen that is consumed by microorganisms to convert organic compounds to a more stabilized form. A diluted wastewater with little organic material will have a relatively low BOD<sub>5</sub> test, while a strong sewage highly concentrated in biodegradable material will have a high oxygen demand as measured by the BOD<sub>5</sub> test. Typical raw sewage has a BOD<sub>5</sub> value of about 200 to 220 mg/l whereas the goal of most wastewater treatment plants is to produce an effluent with a BOD<sub>5</sub> value of less than 30 mg/l.

Nitrogen exists in wastewater in several forms including organic nitrogen, ammonia nitrogen, nitrite nitrogen, nitrate, and Kjeldahl Nitrogen. The nitrites and nitrates are generally in very low concentration in fresh domestic wastewater but will be higher in treated wastewater. Nitrites are not stable and change to either ammonia or to nitrates. The total nitrogen in domestic wastewater ranges from 20 to 85 mg/l, with approximately half of that being in the form of ammonia nitrogen. Kjeldahl Nitrogen is the sum of the organic nitrogen and ammonia nitrogen and is often listed as Total Kjeldahl Nitrogen (TKN). Nitrogen is important in wastewater treatment as it serves as a necessary food for many microorganisms and for algae growth. Nitrogen in a receiving stream may

stimulate the growth of undesirable plants or algae, adversely affecting water quality. Ammonia can be toxic to aquatic organisms found in receiving streams. If this is the case, ammonia limits may be imposed in the discharge permit to prevent toxicity. Ammonia can be converted or oxidized to nitrates in a wastewater treatment system through the use of aerobic treatment processes. The microorganisms that convert the ammonia to nitrate, sometimes called nitrifiers, do not function well in cold temperatures. For this reason, it is difficult in Montana to achieve nitrification in a wastewater system on a year-round basis.

## **NITROGEN CYCLE**

Raw Waste from Ammonia ( $\text{NH}_3$ ) is nitrified or oxidized to Nitrite/Nitrate ( $\text{NO}_2/\text{NO}_3$ ) and then reduced or denitrified to Nitrogen Gas (N).

Phosphorus is present in domestic wastewater in concentrations ranging from 6 to 20 mg/l, most of which is inorganic phosphorus. Phosphorus is essential to the life processes of microorganisms but may also stimulate the growth of undesirable plant species in a receiving stream. As an example, a long, stringy filamentous growth of algae is sometimes observed in the Clark Fork River. Studies have shown that this plant growth is caused, in part, by phosphorous derived from wastewater plants. Many systems that discharge to the Clark Fork River, primarily the upper Clark Fork, are being required to lower levels of phosphorous that is discharged from the wastewater plants. Many communities have also instituted a ban on phosphorus in detergents to lower the influent level of the nutrient that enters the wastewater system. Other sources of phosphorus such as septic systems in the drainage basin are subject to restrictions to lower the discharge of nutrients. Often a basin-wide approach to controlling nutrients is the most effective means to improve and preserve water quality in an impacted stream. Everyone needs to do their part in keeping Montana's high-quality waters clean.

## **II. WASTEWATER ANALYSIS**

### **BIOCHEMICAL OXYGEN DEMAND**

We know that bacteria consume the waste as a food supply for growth and the bacteria use oxygen to perform this task. These facts are the basis for measurement of the "strength" of the wastewater. BOD stands for *Biochemical Oxygen Demand*. In the BOD test, a measured sample of wastewater is put into a bottle of dilution water that contains dissolved oxygen. After five days of incubation at constant temperature of 20 °C (68°F) and no light, the amount of dissolved oxygen consumed is determined. The number of milligrams of oxygen that has been consumed, calculated as if one liter of sample had been used, is recorded as the BOD. When the BOD test is performed on the discharge water, it is a measure of the oxygen demand that may be placed upon the receiving stream. When the test is performed on raw sewage, it is a measure of the "strength" of the wastewater.

BOD is often written as BOD<sub>5</sub>. The subscript <sub>5</sub> means that the test was a five-day test. Five days is the standard test period, although for special purposes other times may be used. Normal domestic sewage will have a BOD<sub>5</sub> from 150 to 250 mg/L, but local conditions may create much higher (or lower) tests. If the sewer collection system allows the infiltration of a lot of ground water or collects storm water, the sewage may be weak and have a low BOD. There may be sources of strong wastewater in a community such as a dairy processing plant or meat packing plant. If these systems discharge to the publicly owned sewer system, the high strength waste may upset the plant. The discharge of a load of septic tank waste or *septage* may impose a very high BOD<sub>5</sub> on the system.

**Septage** is domestic wastewater from cesspools, individual home septic systems, pit toilets, portable toilets, and campgrounds that is delivered to the water resource recovery facility (WRRF) by truck. Septage does not include grease trap waste or any other type of commercial or industrial waste.

Federal treatment standards for publicly owned treatment systems usually require a minimum reduction of wastewater BOD to 30 mg/l as required under the National Secondary Treatment Standards.

As a general average, a figure of 0.17 to 0.22 pounds of BOD<sub>5</sub> are contributed every day to the sewage system for each person in a community. Obviously, this will not be true if strong sewage sources are on the system. Infiltration will not appreciably affect this population equivalent as groundwater has a low biochemical oxygen demand.

Lagoons that discharge large quantities of algae may show a relatively low five-day BOD test as the organic material in the algae cells does not degrade fully in that length of time. Algae cells do, however, have a potentially adverse long-term effect which may impact the receiving stream as the organic matter in the cells degrades. Every effort should be made to minimize the algae content of the discharged water, even though a standard five-day BOD test may show an acceptable level.

## **TOTAL SUSPENDED SOLIDS OR TSS**

The test for *total suspended solids* (TSS) is run by filtering a measured amount of water through a standard membrane filter that has been carefully weighed. After filtering and drying, the filter membrane is again carefully weighed and the difference in weight is calculated to the number of milligrams per liter of water.

## **NUTRIENTS**

It is common for wastewater systems to be required to test the wastewater discharge for the nutrients nitrogen and phosphorous. Most smaller systems will send samples to the state or private lab to perform the analysis for nutrients. Nutrients may be limited in the discharge permit to address a water quality standard that may be imposed upon systems which discharge into a stream with a water quality problem. Additionally, the

total annual load of nutrients may be limited on a discharging system to comply with the non-degradation provisions of the Montana Water Quality Act. For these reasons, operators must collect samples in a proper manner for analysis. Sampling procedures are discussed in Chapter 9 of this manual.



## CHAPTER 3

### I. HEADWORKS: PRELIMINARY TREATMENT

Preliminary treatment is often referred to as the headworks of the treatment system. The headworks may include trash racks, bar screens, grinding, and grit chambers. It may also include flow equalization, flow measuring, sampling, pumping, odor control, and septage receiving. These processes may be in any order and are not usually found in a lagoon system but are becoming more popular as they allow the system to operate more efficiently, reduce maintenance, and extend the times between sludge removal.

#### TYPES OF SCREENING UNITS

Screens remove the larger debris in the wastestream but may allow rags and stringy material to pass through to downstream unit processes. The purpose of the screening units is to physically block entry of large debris, rags, sticks, rocks, wood, and plastics, into the wastewater treatment facility. Removal of the material at the beginning of the treatment process protects the downstream equipment and prevent blockages. The openings in the screens may range from 0.25 to 2 inches apart. Perforated plate screens are more likely to clog or “blind off.” Mesh screens are similar in appearance to a window screen but are made from thicker, tougher wire.

Trash racks are usually used in the bypass channel of the headworks. The trash racks have openings from 1.5 inches up to 6 inches apart and will usually have to be cleaned manually several times a day.

The screening unit may be one of several types: rotary screens, step screens, microscreens, etc. The smaller the spacing (holes) in the screen, the more debris gets captured and the greater head loss across the screen. If the screen is not cleaned regularly the water can build up behind the screening unit and overflow out of the channel. Cleaning cycles may be triggered by a timer or when the difference in water level from one side of the screen to the other reaches a specific set level (head loss) or a combination of both methods. The material removed from the wastestream by the screening processes may be washed, compacted, and landfilled.

Maintenance of screens includes daily inspections of the screening unit for visible and audible indications of malfunction. Regularly cleaning and washing the screen removes material adhered to the screen and not discarded in the hopper. Preventive maintenance of the unit may include lubricating the screen bearings according to the manufacturer’s recommendations. Parts that wear out should be in the plant inventory so they may be replaced when the part is worn.

#### GRIT REMOVAL

Grit removal at the influent reduces wear and tear on downstream equipment. Grit may be fine, discrete, non-biodegradable particles that include sand, cinders, rocks, coffee

grounds, seeds, fruit rinds, and other relatively non-putrescible organic and inorganic substances. Settling of the grit depends on density, size, and shape of the particles. Grit is removed from the waste-stream by reducing the flow velocity. If the velocity is too high, even very dense particles will be pushed through to the next process. If the velocity is too low, excessive amounts of organic material will be removed with the grit. The velocity is decreased to about 1ft/sec allowing the larger denser particles to settle while lighter, less dense organic particles pass on to the next treatment process.

**Velocity** is speed. Velocity can be calculated in two different ways. Velocity is equal to the amount of flow divided by the cross-sectional area of the channel, pipe, or basin. Velocity is also equal to distance traveled per unit of time.

Grit removal systems are called grit chambers. Grit chambers include nonaerated and aerated grit basins, and vortex grit basins. Grit basins may be channels or a mechanical grit removal system. Grit channels may have the grit removed from them manually or with screw conveyors, chain-and-flight collectors, or grit elevators. In an aerated grit chamber, the diffused air is introduced into the unit on one side of the basin to create a spiral roll pattern. The velocity of the roll pattern influences which solids settle. The settled grit is pushed into a hopper on the bottom of the unit by the spiral flow pattern of the water.

A good example of diffused air is an air stone in an aquarium creating fine air bubbles. Compressed air is fed through tubing from a compressor to the air stone. Diffused air in aerated grit basins is similar, but on a larger scale.

An air header is the piece of pipe that runs from the air source (i.e., compressor or blower) into the grit basin and along the bottom. Diffusers are typically mounted directly to the headers.

Vortex Grit Basins are circular basins and the flow is introduced tangentially to create a whirlpool effect. Rotating-paddle-type mixers may be used to achieve proper rotation rate (velocity). The grit will settle to the bottom and be removed by pumping. Grit removed from the system can be deposited directly into dumpsters or truck or it may be concentrated with cyclones or grit classifiers and washed to remove the organics.

Cyclones use centrifugal force in a cone-shaped unit to separate grit and organics from wastewater. There are several types of grit classifiers – free vortex-based, grit dewatering, and conical grit washers.

The grit that is removed should be inspected. Grit that is gray, greasy, or has a rotten egg odor indicates the grit contains large amounts of organic material and the velocity in the grit chamber needs to be higher. If there is little grit being removed, it can be from the velocity being too high or there is very little grit entering the system. Poor grit removal can result in increased wear of downstream equipment, higher maintenance costs, a buildup of grit, and a loss of treatment capacity. The operator needs to balance

the benefits of increased grit removal with the wear and tear on grit removal equipment and equipment which result in increased operations and maintenance costs.

## **INSPECTION AND MAINTENANCE**

Daily inspections and maintenance of the grit equipment includes inspecting for visible and audible indications of malfunctions, regular cleaning and washing to remove adhered materials. Preventive maintenance includes lubricating and adjusting flows and velocities.

Influent flow measuring, and sampling are completed before recycle streams (side stream) flows are introduced to the waste-stream at the head of the plant. Side streams or recycle flows are any flows that are from inside the plant. These can be septage, pumping of water from cell #2 or three back to cell #1, etc. Influent flow can be helpful in determining the diurnal cycle of your system and the actual flow entering the system is beneficial when determining what type of upgrade to the system is necessary. When sampling the influent flow, the operator does not want the side stream flows to be part of the influent sample, as it is not actually part of what is entering the plant. Some plants sample the flow again after the side streams are introduced to the influent to determine the total load on the treatment system.

## **II. TYPES OF LAGOONS**

There are three basic types of lagoons commonly used in Montana.

1. **Facultative lagoons** are the most common and simplest type of wastewater system to construct and operate. Facultative cells are usually 4 to 8 feet deep with about 5 to 6 feet generally accepted as an optimum depth. Facultative lagoons are characterized by having an aerobic surface and an anaerobic lower layer. A type of bacteria called facultative are prominent in these lagoons. Facultative bacteria can exist in both aerobic and anaerobic environments. Facultative cells receive raw domestic sewage and the settleable solids drop to the bottom where anaerobic fermentation and decomposition occurs. Treatment is dependent upon climate and weather conditions. Oxygen for the biological processes that occur in the lagoon cell is provided through wind action, algae—that give off oxygen—and an exchange between the water surface and the atmosphere. The aerobic layer near the water surface is important to prevent the odors that would arise from gases derived from the sludge layer on the bottom of a lagoon. Small community systems may be designed as total containment in which evaporation loss is equal or greater than total water input, including rainfall. In Montana's climate, total containment cells must be relatively large to have enough surface area to evaporate all incoming water; consequently, they are typically used only for smaller communities, resorts, bars and trailer courts.

Design Standards – State of Montana design standards for new facultative lagoons require three cells with piping flexibility to operate the system in parallel or series operational modes. Discharging facultative lagoons are sized to hold 180 days of wastewater flow or, in other words, have a detention time of 180 days. Roughly one acre of surface area is provided in a facultative lagoon for each 100 people that live in a community. Flow measurement must be provided on the lagoon. Liners such as PVC or polypropylene are used to seal the lagoon to meet stringent leakage standards designed to prevent leakage of wastewater into the underlying groundwater table. Total containment lagoons do not discharge and must be sized to have enough surface area on the lagoon cells available to evaporate all incoming wastewater as well as precipitation. Lagoons that do not discharge to surface waters where the treated wastewater is irrigated on crops, must have enough volume to hold the wastewater during the months when irrigation cannot occur.

2. **Aerated lagoons** depend upon mechanical methods of adding supplemental air (oxygen) to the water. The process of aeration generally mixes the water while dispersing or dissolving oxygen in the upper layer of the lagoon water column. Aerated lagoons are usually designed deeper than non-aerated systems, with depths up to 12 to 15 feet. Aerated lagoons are less dependent upon climate and weather. Aerated lagoons are frequently used for industrial wastewater treatment and in situations where limited land area is available. The degree of aeration and of mixing is variable. Some heavily loaded facultative cells have been converted to a modified aerated lagoon by the addition of light aeration. Some aerated lagoons utilize design concepts of an activated sludge system if enough mixing is provided to keep solids in suspension and a sludge return system is used.

Design Standards for aerated lagoons have three cells and piping to operate the system in parallel or series. The cells have about 30 days of total detention time and liners are used to prevent excessive leakage from the system. Aeration can be provided with floating surface aerators or with submerged diffuser systems. The aeration system is designed to provide at least 2.5 pounds of oxygen for each pound of BOD<sub>5</sub> to be removed.

3. **Anaerobic lagoons** are used to treat high strength industrial wastes such as vegetable, fruit, dairy, or meat processing waters, or other high BOD waste. They are efficient in treatment of high strength wastewater, but odor control can be a problem. The anaerobic biological processes, which occur in anaerobic lagoons, produce hydrogen sulfide and other gases that cause odors. Anaerobic lagoons have not been used much in Montana in recent years.

Other terms that are used in reference to sewage lagoons are stabilization ponds or oxidation ponds. The term oxidation pond is usually applied to a cell that follows some other type of wastewater treatment.

The first cell in a series of cells is called the primary cell. The following cells are secondary cells and the last cell in the series may also be called the polishing cell. Cells are usually created through an engineered construction of earthen dikes although fabric baffles are being used occasionally to divide cells into smaller treatment units.

### III. THE BIOLOGY OF WASTEWATER LAGOONS

When wastewater enters a lagoon system, natural decomposition begins to take place. The insoluble settleable solids drop to the bottom. The soluble portions and the suspended solids remain in the water phase. Microorganisms, which are plant and animal life too small to be seen without a microscope, perform the decomposition processes and often do it in a cooperative way. Similarly, pollutants discharged to a receiving stream are decomposed through natural processes. Too many pollutants in a stream causing a large amount of biological decomposition in the water body can result in poor water quality and undesirable conditions.

We like to think of bacteria as little "bugs," but they are not insects. Bacteria are the main workers in the decomposition (or stabilization) process. For most types of organic material, there is generally a form of bacteria that will utilize it for food to obtain energy and to generate new bacterial cells. The fallen log in the forest is partially consumed by bacteria. There are varieties of bacteria that will consume oil. And there are bacteria that will use the waste that comes down the sewer as a food supply. There are thousands of varieties of bacteria and a lagoon will contain billions upon billions of them. They perform valuable service in wastewater treatment and society is in their debt for taking on an unpleasant task.

Bacteria require oxygen in some form for them to exist and to grow. In the case of aerobic bacteria, they live where there is free oxygen dissolved in the water. These aerobes live in the upper levels of a wastewater lagoon which contains free dissolved oxygen.

Anaerobic bacteria must obtain their oxygen by decomposing oxygen containing compounds, such as nitrates or sulfates, to find their supply of oxygen. Some of the nitrate is reduced to ammonia and some of the sulfur compounds are reduced to hydrogen sulfide. Both ammonia and hydrogen sulfide are water soluble, but under some conditions the ammonia and hydrogen sulfide can escape into the air. These are odorous compounds. Hydrogen sulfide is a gas and smells like "rotten eggs." A treatment plant that produces the odor of rotten eggs is probably partially in an anaerobic state. As anaerobic bacteria can work on sulfates to produce hydrogen sulfide, water that contains

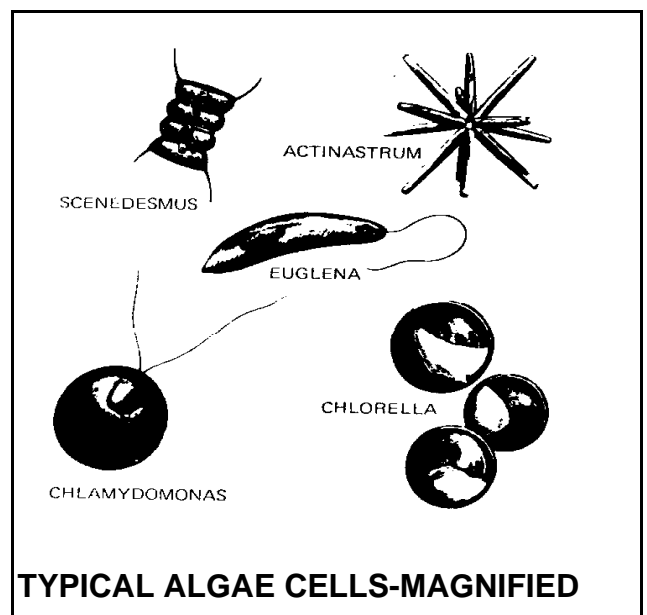

**TYPICAL ALGAE CELLS-MAGNIFIED**

high sulfates will produce more odor when conditions are anaerobic. Anaerobes normally live in the bottom zone of a lagoon cell.

Facultative bacteria can live and work both with and without free oxygen present. They largely inhabit the intermediate level zone in an unmixed lagoon.

## **ALGAE**

Algae are single cell or multiple cell plants that are microscopic, although clumps and mats of them may be seen at times. Algae, like other plants, contain chlorophyll and can perform the process of photosynthesis. This process, which requires sunlight, consumes carbon dioxide, and releases free oxygen. The free dissolved oxygen that the algae produce is of vital importance to treatment as it encourages aerobic bacterial decomposition and conversion of the organic material. Algae will be found in the upper, aerobic area near the surface of the water. They require certain nutrients, principally carbon, nitrogen, and phosphorus, all of which occur in wastewater. Algae flourish, grow, and produce oxygen during the daylight hours, but at night they consume oxygen. In combination with the continuous demand for oxygen by bacteria, this means that the oxygen concentration in the water will be highest in late afternoon and lowest just as the day begins.

There are many varieties of algae and it is important for a wastewater lagoon operator to recognize two general classifications: (1) Green algae which give a lagoon a green color and are a sign of a good healthy condition. They are prominent when the waste has a high nutritional value and generally when pH is higher. (2) Blue-Green algae which can appear when nutrient or pH levels are low, or when the green algae disappear due to other environmental conditions. The appearance of blue-green algae is a sign of poor conditions in an unmixed lagoon. Blue-green algae can develop into floating clumps and mats and cause a decrease of dissolved oxygen. The pH will be lower and odors noticeable.

Algae require carbon dioxide (CO<sub>2</sub>) to multiply and grow. They obtain this from free carbon dioxide that is dissolved in the water. As carbon dioxide is a weak acid when dissolved, it plays an important part in the pH balance of the water. When algae remove CO<sub>2</sub> from the water it drives the pH up, (more alkaline), and when algae action is slow, the pH will go down. At times of high sunshine levels and plentiful nutrients, the algae can cause the water pH to go up to 9 or 9.5.

## **HIGHER FORMS OF MICROORGANISMS**

**Higher Life Forms.** A higher form of microscopic life like paramecium and daphnia exist in lagoons and feed on green algae or bacteria. They are more likely to be found in the second or third cell of a lagoon system, as they require a plentiful oxygen level. Protozoa consume only the green algae. It is possible for these predators, especially daphnia, to multiply rapidly into a "bloom" and nearly destroy the green algae

population. There are a variety of other higher life forms found in lagoons including rotifers, protozoa, chironomides, mosquito larvae, and worms.

In a healthy lagoon, all the above microorganisms are at work together. The organic settleable solids that drop to the bottom are used by anaerobic bacteria. As the solids are converted into a stabilized humus-like material, soluble organic acids are formed which enter the water phase. Nitrogen compounds that arrive in the wastewater are converted partly into ammonia and into free nitrogen, some of which escapes into the atmosphere. Nitrogen also serves as a nutrient for production of new algae cells. Some sulfur containing compounds release hydrogen sulfide to the water. In the bottom sludge, a considerable amount of the solids are converted into methane gas, which escapes from the pond surface.

While the anaerobic bacteria are working in the lower zone of a pond, aerobic bacteria are active in the upper levels where there is a supply of free oxygen. The oxygen is supplied by algae in this zone, and by wind action on the surface. Aerobic bacteria utilize organic material that arrive in the wastewater and that which is released from the anaerobic sludge layer on the bottom. The ammonia, hydrogen sulfide and other byproducts of the anaerobic decomposition process may release an additional load to the aerobic layer. The extent of this aerobic layer varies depending upon the time of year, the amount of mixing created by wind and the density of the algae at the surface. The presence of duckweed can also reduce the sunlight and consequently the production of oxygen by algae. The figure below shows a graphic illustration of the processes which occur in a typical lagoon cell.

The organic materials are consumed by bacterial action and changed into bacterial cells and algae cells. The dead bacteria cells and dead algae cells eventually settle to join the sludge on the bottom. As the years pass, this sludge layer slowly grows. The process in which the sludge is transformed into a stable humus-like material is called stabilization. In a lagoon receiving primarily domestic sewage, this sludge layer can increase depth at a rate of about one half an inch a year. Old sewers which allow leakage into the pipe system will also carry inorganic grit and sediments into the sludge layer. This material will not breakdown biologically and will continually accumulate, eventually requiring removal.

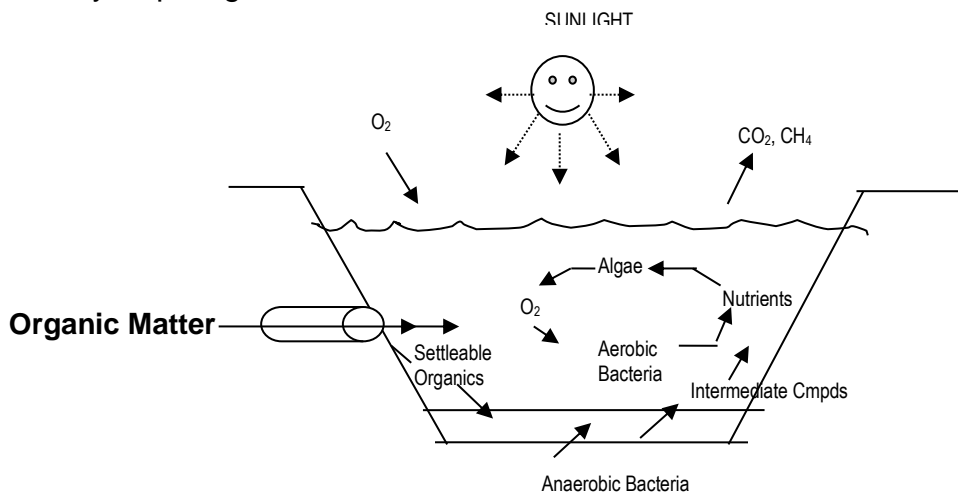

### Biological Activity in a Facultative Lagoon

## CHAPTER 4

### I. FACULTATIVE LAGOONS

There are many facultative lagoons in use in Montana. Some were constructed 40 or 50 years ago and are still in use. A facultative lagoon system is a simple system and operation is relatively inexpensive in comparison to more complex facilities. Lagoons work well for small communities where adequate land is available to site the system. However, a lagoon has limitations and must be understood and watched carefully if it is to perform satisfactorily. Facultative lagoons need a good supply of algae to help supply the oxygen for aerobic bacterial action. Wind and atmospheric oxygen also provide oxygen to the microorganisms in facultative lagoons. Algae cells are organic and when discharged into a receiving stream can be a pollutant. They are difficult to remove, so the best approach to this problem lies with the watchful eye of the operator who must observe the system, keep records, and test to determine the best time to discharge. Facultative lagoons generally will remove only small amounts of nutrients and if a community has nutrient limits in their discharge permit, other technologies may be necessary.

The operator of a facultative system has limited control over the efficiency of the biological processes which take place in the lagoon. It is possible to put the cells into series or parallel operation for changing conditions or the level at which water is drawn from the lagoon is controllable in many systems. Also, the operator has some control over how and when the system discharges. However, Mother Nature has a major impact on treatment performance and weather and climatic conditions are very unpredictable. There are general concepts that the operator can use to optimize system performance in a facultative lagoon which are discussed in this chapter.

### SEASONAL CHANGES IN OPERATION

#### WINTER

Cold weather slows down all biological activity. When temperatures drop, the anaerobic digestion of bottom sludge slows down, and sludge may begin to accumulate. The colder temperatures also slow the aerobic activity. With lower biological rate, the demand for oxygen is lower. With shorter days and lower sunlight intensity, algae reduce in numbers and activity. Ice cover and snow on top of ice reduces sunlight intensity as well. As a result of the slow treatment process, winter may not be a good time to discharge water. There is often a time in late fall or early winter when BOD tests on the treated water are acceptable and the algae concentration is lower. This is a good time to discharge and to draw down the levels enough to allow storage volume in the pond to contain water through the winter months. Lagoons constructed to current design standards should have 180 days detention time at design flows. This amount of volume is needed in cold climates to hold the wastewater in the lagoon during the winter to allow for adequate treatment levels.



## **SPRING**

As spring temperatures begin to melt the snow and ice cover, the pond will warm and reach a turnover condition. The water surface will warm before the bottom of the lagoon and, strangely, water at top of the lagoon is slightly heavier than water at the lower level. Normally warmer water is lighter than colder water except when the water temperature is near the freezing point (ice floats on water). The heavier surface water will roll to the bottom, and the anaerobic bottom water with some suspended sludge will rise. This condition may continue to exist for one to three weeks. The water is murky, dirty looking and smells because the anaerobic conditions release hydrogen sulfide to the air. This is the time that the operator will hear from the townspeople!

When the turnover or temperature inversion has ceased and when the water in the final cell looks good again, it may be a good time for another discharge. Some operators like to discharge just before the turnover occurs. Every lagoon is a little different and every year is different, so it is a matter of operator judgment and understanding of the system to determine when these discharge periods are best. At this time the operator should take samples for testing and if the results are within the permit requirements, discharge could begin or resume.

## **SUMMER**

Warm summer temperatures increase the rate of bacterial action. An increase of 10°C in the water can double the rate of biological activity. The sludge layer decreases, releasing high organic loads to the water and the oxygen demand increases dramatically. The longer daylight hours and the increase in sunlight generate high algal growth and bacterial activity. The pond turns a deep green color. Maintenance activities increase as plants grow including the removal of weeds, cattails, algae mats, and other undesirable elements for good system operation.

## **FALL**

Many operators find a period in the fall when effluent tests are good for discharge. This also allows them to lower the water level sufficiently to discontinue discharge during winter months when effluent tests may not be good. The ponds may turnover again in late fall or early winter.

## **II. OTHER OPERATIONAL CONSIDERATIONS**

### **SYSTEM FAILURE**

The failure of a lagoon system is evident through the performance of the system, specifically the inability of the lagoon to meet the requirements imposed upon the system through the discharge permit. Performance problems can sometimes be detected through a physical inspection of the lagoon. The color of the lagoon water,

rather than being a healthy green, will turn gray or black. Odorous algae mats may be present. Septic odors will likely be present, often very strong and indicative of a release of hydrogen sulfide gas. While many of these conditions may also be present during spring turnover, the thermal turnover condition will end after a few weeks whereas failure will be more long-term. While lagoons are fairly forgiving as a treatment process, failure of the system as described here is indicative of a serious problem. The lagoon may simply be too small for the hydraulic or organic loading that the system is receiving. A toxic discharge may destroy all biological activity in a lagoon cell, requiring some time for recovery.

## **MIXING**

While mixing in a lagoon is important the only effective energy for mixing in a facultative lagoon comes from wind. Wind will stir the surface and move the aerobic layer to deeper levels. This will moderate overloading conditions and lead to more complete treatment. Without any wind or waves, a thin layer of high algae concentration tends to accumulate at the surface. Stratification can occur and result in anaerobic conditions in the lagoon cell. Stratification is the condition where the surface becomes much warmer than lower levels. The warm surface is not easily mixed into the main body of water. A poor weather condition for a facultative lagoon is a hot, sunny, and quiet week. It is difficult to combat stratification. Some have tried motorboats with variable success. Absence of mixing can result in poor system performance and potentially effluent violations. Trees and bushes should not be allowed to grow around the lagoon as they reduce the wind action. Wind driven mixers have been used effectively to improve mixing conditions in facultative cells.

## **SHORT-CIRCUITING**

The operator should be on the lookout for signs of *short-circuiting*. *Sometimes it is possible for water to find a short path from the inlet to the outlet* so that treatment is incomplete. Under some fall or spring conditions it may be possible to see an unfrozen lane leading from the inlet toward the outlet during discharge. The best situation is when the entire pond is being effectively utilized in treatment. There are several conditions that aggravate short-circuiting. Mostly they are a result of improper design or construction, but some can be helped by operator attention. Causes of short-circuiting include the following:

1. Poor placement of the inlet and outlet piping. The outlet should be at a far corner or side from the inlet and generally, the inlet and outlet should be as far apart as possible.
2. An irregular bottom. Some lagoons were built in a natural gulch or draw. This may be an inexpensive method but may lead to short-circuiting.

3. Prevailing winds. Winds tend to move water near the surface and if the outlet is on the downwind side, the wastewater flow may short-circuit, leaving the upwind areas in the cell little used.
4. Cattails, willows, rushes, or weeds growing in the cells restrict water movement. This is another reason they should be kept under control.
5. Thermal stratification. During colder months, the incoming sewage will be warmer than the lagoon water. As warm water is lighter than cold water, there can be a tendency for the warmer water to "float" over a colder layer. Mixing can correct this. Also, changing the level of withdrawal at the outlet can mitigate a surface short circuit.

## ORGANIC LOADING

Facultative lagoons are designed for a specific rate of organic loading. Organic loading is defined as pounds of BOD per acre of surface based on the concentration and flow of raw sewage coming into the lagoon system. The loading allowed by regulatory agencies varies, depending upon the climate. In Montana most facultative lagoons are designed for a loading of about 20 pounds of BOD per acre. For normal domestic sewage, each person contributes about 0.2 pounds of BOD per day. So, for a community of 1,000 population, the average load to the lagoon would be 200 pounds per day, and if we use the 20 pounds BOD per acre loading, then the community would require a lagoon with 10 acres of surface area.

The guidelines for design also recommend at least three cells with piping flexibility for parallel or series operation. One reason for this requirement is to give the operator the choice of parallel or series in case the first cell should become overloaded. Multiple cells also reduce the potential for short-circuiting.

## OVERLOADING

Overloading can cause serious problems. Overloading is quite evident by the odor and appearance. When overloading occurs, the condition may sometimes be corrected if the first two cells are placed in *parallel operation*. Normally, the best performance in a lagoon system is in a *series* flow path – where sewage passes from Cell #1 to Cell #2 then Cell #3. But if Cell #1 cell shows signs of failure (i.e., septic conditions) due to excessive loading, switching to parallel flow into Cell #1 and Cell #2 can help unload the failed cell. The parallel flow path effectively splits the organic loading which the two cells receive from the raw sewage entering the system. The drawings below provide a schematic of series and parallel operational flow paths.

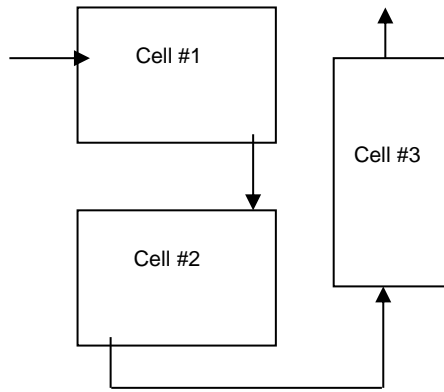

Series Flow

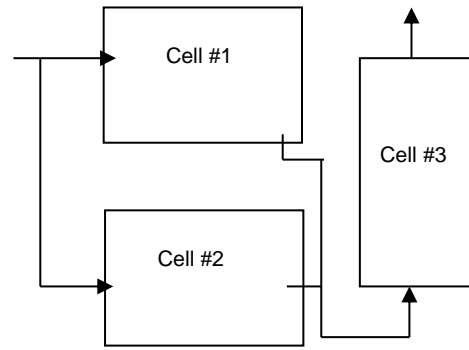

Parallel Flow

### EXAMPLE

Suppose there is a community of about 1,000 people which has a lagoon system consisting of three five-acre cells. The normal loading to the lagoon system would be about 200 pounds of BOD total. The load to the first cell when operated in series would be 200 pounds BOD divided by 5 acres, or 40 pounds BOD per acre. It may operate satisfactorily at this loading rate. However, if an increased load from some source raised the total BOD load to 250 pounds per day, the load to the first cell would be 50 pounds per acre and there is a probability of overloading. If the first two cells are put into parallel operation, each receives one half of the load and the loading drops to 25 pounds of BOD per acre which is an acceptable load.

Often an overloaded lagoon is caused by excessive organic loading, flow, or both and must be corrected through construction of system upgrades. Alternatively, reducing the total load would help. Sources of exceptionally high BOD include food and dairy processing, meat packing, and the disposal of septic tank pumping into the sewer system. Pumping's from septic tanks, campground holding tanks, portable toilets and similar facilities have a very high BOD and can easily overload and upset a lagoon system. In general, the deposit of septage into a lagoon should not be allowed. The material can be land-applied or taken to a mechanical treatment plant which may be more amenable to accepting the heavy loads.

*Recirculation* by pumping from the outlet back to the inlet has helped cure overload odors and problems. The outlet water will be high in dissolved oxygen and serves to provide DO (dissolved oxygen) to the incoming sewage and will help reduce odors. Pumping 1 part of recycle to 6 parts of influent is suggested. Sodium nitrate has been used to help eliminate odors. The nitrate provides a quick source of oxygen, and may help temporarily, but does not cure an overloaded condition. An application of 100 pounds per acre is reported to be helpful with a continuing dose of 50 pounds per acre if the odors persist. It reacts rather quickly but must be distributed over the entire pond to be effective. If the odor problem reoccurs, the system is probably chronically

overloaded and major changes, such as addition of aeration equipment or increase in lagoon size will need to be considered.

### **III. GENERAL OPERATION AND MAINTENANCE**

A facultative lagoon should be visited regularly, daily if possible, during the workweek. Each visit should be recorded in a logbook, or data sheet. See Appendices for an example of a log sheet.

#### **DAILY LOG**

The data required is not very extensive but should include the flow rate and any sampling or testing that is done. It should also include notations concerning the weather, if sunny or cloudy, quiet or windy and the temperature. The operator should make notations about the appearance of each cell such as if cells are a healthy green or if scum mats are present and describe the odor (if any). Of course, the discharge rate and appearance are important if the system is discharging. Many operators have developed their own record keeping and find it very useful as it allows them to anticipate conditions and make provision for actions as needed. Log sheets should be kept in an organized manner and bound in a notebook, available for use by future operators.

A list of daily notations in the log could include these items:

1. Note if any scum, floating debris, or algae mats are present. Rake off large accumulations, if possible.
2. Look for signs of burrowing animals and eradicate if found. Fill all holes.
3. Note the smell and appearance of each cell. Is there any odor of anaerobic or septic condition?
4. Check for cattails, reeds, or willow growth. Remove plants, taking care not to damage the liner.
5. Note condition of dikes. Any erosion? Look for exposure of liners. Some synthetic liners are degraded by exposure to sunlight. Recover with earth. Check exposed liners for damage, tears, split seams, and other conditions which would require repairs.



Poor Fence Condition!

6. Note fencing condition and repair as needed. Keep gates and locks in good condition. Unauthorized persons should not be allowed access. Make sure that warning signs are in place and in good condition. Owners of lagoons near inhabited areas should take all necessary measures to prevent unauthorized access.  
**Children have drowned in lagoons in Montana!**

7. Check the inlet structure. Clean trash from bar screens and dispose of it.

8. Check the draw-off structure. Which level is being used? Is it the optimum level? It is important to maintain water two feet above the solids layer to provide treatment of the wastewater and reduce odors from the lagoon, even following draw down. Make gradual changes in lagoon level rather than allowing drastic differences in water surface elevation.

9. **Exercise all valves on a periodic schedule to make certain they operate properly.**

10. Look for evidence of short-circuiting and correct the problem if the capability is available to the operator, such as changing flow paths.

11. Check around the perimeter of cells for evidence of leakage or seepage.

## WEED CONTROL

Weeds should be kept under control. Weeds along the edges will collect floating debris and scum, which is unsightly, generates odors, and provides a place for mosquitoes to breed. Weed control includes weeds along the entry road, on the berms, and the slopes. A sickle mower is useful for this task as it can be worked on dike slopes. Great care should be taken when mowing sloping areas. More than one tractor has been overturned. Deep-rooted plants, such as alfalfa and trees (willows are bad), can penetrate the lagoon liner and cause failure of the bank. Muskrats and gophers are especially damaging and must be kept out for they can burrow a hole right through the dike. It is not a good idea to pasture horses or cattle in the lagoon area. They will break down the banks as they wade into the water.

Do not use herbicides at the water level, or where residues can be washed into the lagoon. Herbicides and insecticides can only be applied by a person with a license for

using such chemicals. Approval from DEQ is required before use near the lagoon or discharge area. These chemicals can be very toxic in surface waters!

Control of cattails growing in or around the lagoon is very important. Uncontrolled cattail growth can cause pond failure. The roots of cattails can penetrate the clay liner of a pond allowing seepage to occur. The more numerous the cattails, the greater the possibility of a seepage problem. Cattails reduce the oxygen intake of a lagoon in many ways, such as reducing the wave action, wind action, and sunlight penetration. Cattails also encourage mosquito growth, serve as a harborage and food source for certain burrowing rodents, and add an additional organic BOD demand. Suggested methods for cattail control are:

1. New growth cattails can be pulled by hand before the plant produces its extensive root system, which are almost impossible to pull once established.
2. Mowing will keep vegetation low and frequent mowing may reduce cattail population over time by depleting root food reserves.
3. Lower the water level to expose cattails, and then burn with a gas burner. Burning will get rid of the top growth, but like mowing, needs frequent repetition to control regrowth.
4. Allow the surface to freeze at a low water level, raise the water level and the floating ice will pull the cattails as it rises. Best results are obtained when the cattails are young.
5. Increase water depth to above tops of cattails for to kill the plant.
6. As a last resort, cattails can be sprayed with a state registered herbicide.

**All aquatic herbicide applicators must be licensed by the Montana Department of Agriculture prior to any application. Approval from the Montana Department of Environmental Quality (444-6697) is required prior to using an herbicide in or near a discharging wastewater lagoon.**

## **EROSION CONTROL**

Erosion of the banks by wave action can be a problem. If allowed to go unchecked, waves can seriously narrow the dike and cause shallow areas along the bank. Sloughed materials can lead to shallow weed growth in the lagoon cell. Some synthetic liner materials can be seriously damaged if cover materials are eroded and the liner is exposed, with damage occurring after only a relatively short exposure of the liner to sunlight. If erosion becomes a problem, the long-range solution is usually placing riprap on the problem bank. Riprap should consist of clean large rock, typically 6" to 12" in size. Do not dump large concrete blocks, car bodies or other junk along the banks.

Synthetic liners usually require a soil cover which is then covered with riprap. Materials comparable to the original construction should be used to repair exposed liners.



## SLUDGE MONITORING

All lagoons will accumulate sludge, leading to the eventual need to remove the material. Facultative lagoons, by nature of their size, can hold sludge accumulations for several years. Newer lagoon designs are sized specifically to hold a certain amount of sludge, whereas older systems may have no excess storage volume available for sludge. Operators should periodically measure sludge depths in each of the lagoon cells, using a grid to establish position of sludge deposits. A record should be maintained on the sludge accumulations and the depths should be rechecked, roughly every five years. A sludge judge is a clear tube measuring  $\frac{3}{4}$ "-1  $\frac{1}{4}$ " in diameter, and usually stands around 15 feet tall but can be adjusted longer or shorter by adding or removing tubing sections. The wastewater flows in through a check valve on the bottom that allows water to flow in but will not let it out until it is opened manually by pushing the bottom against a solid surface. There are rings around the sludge judge every foot, so the depth of the sludge can be measured which allows the collection of a water/sludge core, making it a good tool for measuring sludge depths. The DEQ or the Montana Rural Water Systems can assist operators in sludge monitoring. For safety reasons, an operator should not do the work alone.



## CHAPTER 5

### I. AERATED LAGOONS

As described in the previous section, a facultative lagoon depends, in part, upon algae and their photosynthesis as well as wind to provide the oxygen for bacteria to consume the organic waste. The system is very dependent upon weather and climate conditions and a large surface area on the lagoon to ensure that adequate oxygen transfers from the atmosphere into the lagoon. Treatment is not always optimum and if a continuous discharge is made, there may be permit failures part of the year. Treatment slows during winter and the effluent BOD may rise to the point where the limitations of the discharge permit are exceeded. During warm summer months, algae growth accelerates. Suspended algae flow out with the discharge water and may cause a high suspended solids test. Although the process is inherently simple to operate, the operator of the facultative lagoon system has few control options. As land becomes more valuable in Montana and communities grow, often an economic analysis of treatment options will favor an aerated lagoon over a facultative pond system. Aerated lagoons use a supplemental source of oxygen provided by mechanical equipment. In general terms, an aerated lagoon requires about one-sixth of the total pond volume of a facultative pond to achieve comparable levels of treatment.

The aerated lagoon is a good system for small to moderate sized communities not required to produce effluent with advanced levels of treatment prior to discharge. They do require more energy and operator attention than a facultative lagoon, thus operating budgets for a community using an aerated lagoon will be greater than for a community with a facultative lagoon.

There are several different aeration systems used in aerated lagoons, including the following types:

- Fine bubble diffusers
- Coarse bubble diffusers
- Floating aspirating aerators
- Floating surface mixers
- Jet aeration

There are two main functions that any aeration system should perform, as follows:

**Aeration:** To transfer atmospheric oxygen from the air to the wastewater as needed to supply the needs of aerobic and facultative microorganisms.

**Mixing:** To keep the contents of the lagoon from stratifying and to distribute the oxygen throughout the upper portion of the cell.

## PARTIAL MIX AERATED LAGOONS

Most aerated lagoons in Montana are *partial mix* designs. This means that some settling of solids and anaerobic decomposition on the bottom occurs. Enough mixing is provided to disperse *dissolved oxygen* (DO) into the upper levels of the cell. The aeration equipment may be designed to operate continuously, or to run intermittently. Many aeration systems experience freezing problems if run on an intermittent basis during the coldest winter months in Montana. Operators frequently will run the aeration system continuously in the winter to avoid freezing problems and the associated maintenance that might be needed to free up the system.

Aeration systems can be controlled with a timer so that the operator can set the aeration timing to serve the characteristics of the treatment plant as well as to save energy. In general, it is not wise to keep the aerators turned off for a long period of time (several hours.) The suspended bacteria begin to settle, and quiet conditions tend to encourage algae growth or septic conditions. The operator should test for dissolved oxygen to be sure that there are consistent levels in the cell. Generally, about 1-2 mg/l is sufficient. If the system DO is higher, the aeration schedule can be reduced, but in an aerobic system, the DO should not be allowed to get below a concentration of 1 mg/l as it is unhealthy for the bacteria. Based on observation, the operator of an aerated facility should determine the best timing and schedule for aeration. As algae are present, some DO is supplied from them and can vary with the time of day, similar to a facultative cell. Dissolved oxygen tests should be run at the same time each day. Morning is a good time before the effect of algae growth becomes more pronounced later in the day.

Engineers designing submerged blower and fine bubble diffuser aeration systems may utilize variable speed drives to provide turndown capability on aeration to save energy. The variable speed drives allow the operator to turn down the speed of the blower motor, resulting in a corresponding reduction in the output of the blower. While these systems allow a more effective use of the aeration equipment, the variable speed drives increase the capital costs of the blowers and add operational complexity to the system.

Aerated lagoons are usually much deeper and smaller in area than cells without aeration. A depth of 12 to 15 feet is normal. If a submerged system is being used, the added depth increases the efficiency of oxygen transfer and reduces the number of aerators needed to achieve mixing. The *organic loading* of aerated lagoon cells is considerably higher than facultative cells. A non-aerated cell in Montana may be loaded at 20 lbs BOD per acre, but an aerated cell could be loaded with up to 75 to 100 pounds BOD per acre. The actual loading rate is limited by the amount of oxygen the aeration system can supply. The aeration system must be designed to provide 2.5 pounds of oxygen to the wastewater for each pound of BOD which must be removed, as needed to meet effluent standards. Aerated lagoons will be effective in nitrifying ammonia compounds during the warmer months of the year but will typically lose nitrification capability in the wintertime. Some discharge permits require ammonia removal in that ammonia compounds can be toxic to aquatic organisms.

## COMPLETE MIX AERATED LAGOONS

The complete mix lagoon approaches the characteristics of an activated sludge plant, a term used for mechanical treatment facilities considerably more complex than lagoon systems. Some complete mix lagoon designs use a return of settled sludge to the first cell. The returned sludge, when used, is active biological material. Clarification following the complete mix basin is needed to settle biological solids and allow for return of the “activated” sludge. This type of complete mix lagoon is rare in Montana in that a mechanical treatment plant will typically be selected over a complete mix lagoon system if a high degree of treatment performance is warranted. Energy and operational costs associated with a complete mix aerated lagoon are significant. New designs are being developed which use complete mix lined earthen lagoons and concrete clarifiers. These systems may allow lagoons to achieve nutrient removal and may be effective for small communities which are required to have a highly treated effluent.

## AERATED-FACULTATIVE LAGOONS

There are some facultative lagoons that have been converted to aerated lagoons by the installation of aerators. There are varying degrees of aeration in these systems ranging from “almost facultative” with light aeration, to a more typical partially mixed lagoon design. Facultative lagoons, with their shallow depth and large volume, are not well configured to be converted to an aerated lagoon without substantial reconstruction. The modified lagoon may generate excess growths of algae. Putting aerators in a facultative lagoon may improve the performance of an overloaded facultative lagoon but it will not approach the effectiveness of a properly designed aerated lagoon system.

## II. AERATION SYSTEMS

### SURFACE AERATORS

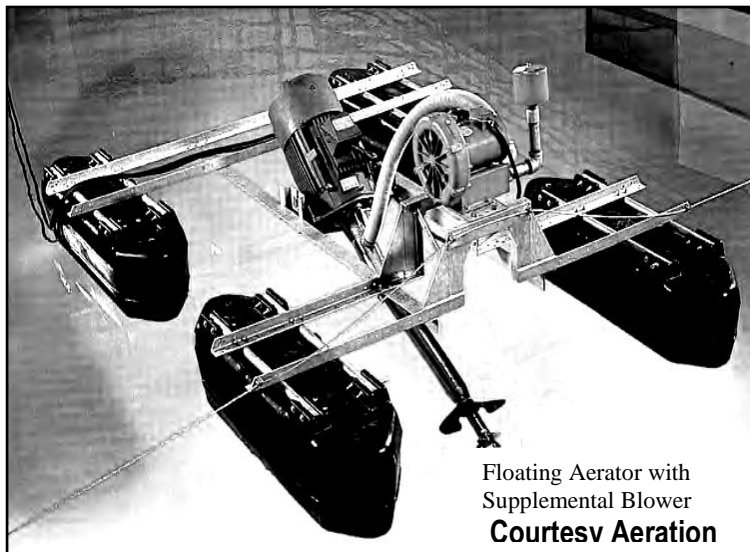

Surface aerators are electrically powered machines which float on the lagoon water surface. They may be mounted on pier foundations or may be supported by a large doughnut-shaped float. The motor drives an impeller that throws the water into the air where it absorbs oxygen. The action of the impeller also creates a well-mixed zone for a considerable area around the aerator. Few municipal lagoons in Montana use floating surface aerators as

there have been problems with ice formation on the machinery and on the floats. Ice has been heavy enough to sink older style floating aerators of the paddle-impeller type, but manufacturer improvements have eliminated much of this problem. Pier-mounted surface aerators are used in certain industrial applications in the state.

## FLOATING ASPIRATING AERATORS

Floating aspirating aerators are being used at several Montana municipal lagoons. They use floats or pontoons with the aeration unit suspended between the floats. The electrically driven aerator consists of a long hollow shaft suspended at an angle to the water with a propeller on the end of the shaft. Air is sucked down the propeller shaft and driven as small bubbles down into the water. The angle of the shaft and the direction that it is pointed determines the mixing movement of the cell. Usually several aerators are arranged in a pattern to develop a circular movement in the cell. Floating aspirating aerators are not as prone to winter problems as floating mechanical surface aerators but do require the operator to take precautions. If temperatures are very low, it is best to keep the aerators running otherwise the rotating equipment may freeze in place. Once frozen they can be difficult to free in severe weather. Some models may be equipped with heaters to assist in fighting the icing problems. It is treacherous to go out on the ice to pour hot water or antifreeze into the aerator and the practice should never be undertaken by the operator.

## FINE BUBBLE SUBMERGED AERATORS

Fine bubble submerged aerators can be efficient in oxygen transfer, resulting in a savings of energy in comparison with other types of aeration systems. In general, the smaller the bubble that an aerator produces, the more efficient the system will be. The surface area to volume ratio on small bubbles is greater than large bubbles, allowing for more area for the oxygen to pass from the air bubble into the wastewater. However, some fine bubble (diffused air) systems used in the past have had problems with maintenance including difficult access and plugging. Several systems using rigid plastic piping with very small slits cut into the pipe required complete replacement, after system failure occurred due to plugging. New systems utilizing plastic membrane diffusers have been developed which have shown satisfactory performance results in terms of maintenance. As air is applied, the membrane sleeve expands, and a small bubble is discharged. Upon shutoff, the membrane contracts which limit

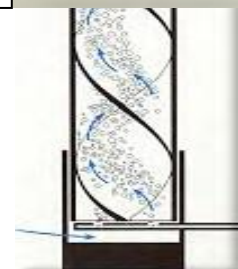
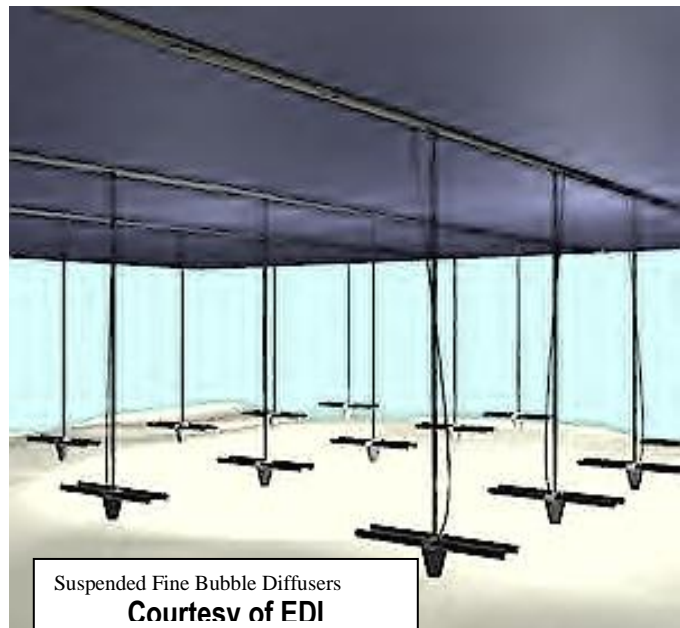

“Polcon” Helixor

backflow into the system and plugging. After a period of time (approximately 5-7 years) the membranes lose their elasticity and must be replaced. While fine bubble diffusers can be effective in saving energy costs, system operators and owners must be prepared to pay the operational costs associated with the replacement of the diffuser membranes. To achieve full benefit of the energy savings potential of the fine bubble diffuser, the operator must utilize the blowers effectively with timer control or variable speed drive to avoid over-aeration of the lagoon contents. Fine bubble diffuser systems require blowers and air distribution piping to deliver the air to the diffuser units, located near the bottom of the aeration cell.

## **STATIC TUBE AERATORS**

Static tube aerators are generally considered a “coarse” bubble diffuser. Aeration systems using these diffusers can be low in maintenance but can be relatively expensive to run as they are not very efficient, resulting in the need to provide larger blowers and more energy to power the blowers. The diffuser unit is a plastic tube standing upright on the lagoon floor, anchored over an air lateral. Air enters the diffuser arrangement through a relatively large diameter hole in the lateral and the air rises through the tube where the oxygen transfers into the wastewater. Manufacturers have devised ways to increase the time of air/water contact in the tube and to form a smaller bubble, thereby to increase the efficiency. Static tubes are not subject to winter problems as they are below the ice. A good static tube aerator is an excellent mixer as the rising air creates a pumping action vertically. Static tube aeration systems have been used many years in Montana with good performance and very limited maintenance needed on the diffuser system. As with fine bubble diffusers, the static tube aeration system requires blowers and an air distribution system to deliver the air to the mixing aerator device.

## **BLOWERS AND PLANT PIPING**

Blowers and plant aeration systems that discharge air under pressure through diffusers will require blowers to compress the air in the volume required and at the pressure necessary to move the air to the bottom of the lagoon cell. Blowers typically are located adjacent to the lagoon cell in a blower building, which would also contain the controls and instrumentation for the blowers. A system of pipes, often welded steel, will carry the air to the submerged diffusers. From the main air header, laterals will branch out into the lagoon cell where air is dispersed to the diffuser unit. Valving will typically be used on each lateral to allow for a balancing of air throughout the system. Plastic (HDPE) piping is frequently used for the air laterals and the feeder lines to the diffuser units.

The two types of blowers most often used in aerated lagoons include the centrifugal blower and the positive displacement blower. A positive displacement (PD) blower discharges a fixed volume of air over relatively wide range of discharge pressures. PD blowers can be noisy and require silencers to baffle inlet and discharge air noise generation. The PD blower is a good choice for a smaller system. The speed of the

blower can be controlled through changing sheaves on drive pulleys or use of a variable speed drive. Use of speed control or, alternatively, timer operation will allow the operator some turndown capability to allow for energy savings.

Centrifugal blowers are found in larger systems where large volumes of air are required. The blower operates somewhat like a centrifugal pump where rotating vanes force the air from inlet to outlet. While quieter than PD blowers, centrifugal blowers emit a high-pitched whine and silencers are necessary. Turndown capacity can be provided through throttling of the inlet to the blower although variable speed drives are sometimes used on centrifugal blowers. The centrifugal blower operates within a limited range of pressure differential; thus, their use is restricted to systems where the water level is kept relatively constant.

## **WIND POWERED MIXERS**

Wind powered mixers are available which have been effective as mixing and aeration aids for facultative lagoons or to supplement aeration systems in aerated lagoons. The equipment is surface mounted on a float. These units depend upon wind to turn a vertically oriented rotor which in turn operates a submerged impeller. An advantage is that no electrical power is used, although some units utilize an electric motor which operates when the wind is not blowing. While the wind powered mixer undoubtedly increases the transfer of oxygen from the atmosphere into the wastewater DEQ has considered the equipment as “mixers” rather than aerators. Consequently, more effective means of providing air must be incorporated into aerated lagoon designs. The mixers have been used effectively in existing facultative lagoons to improve performance through better mixing and oxygen dispersion.

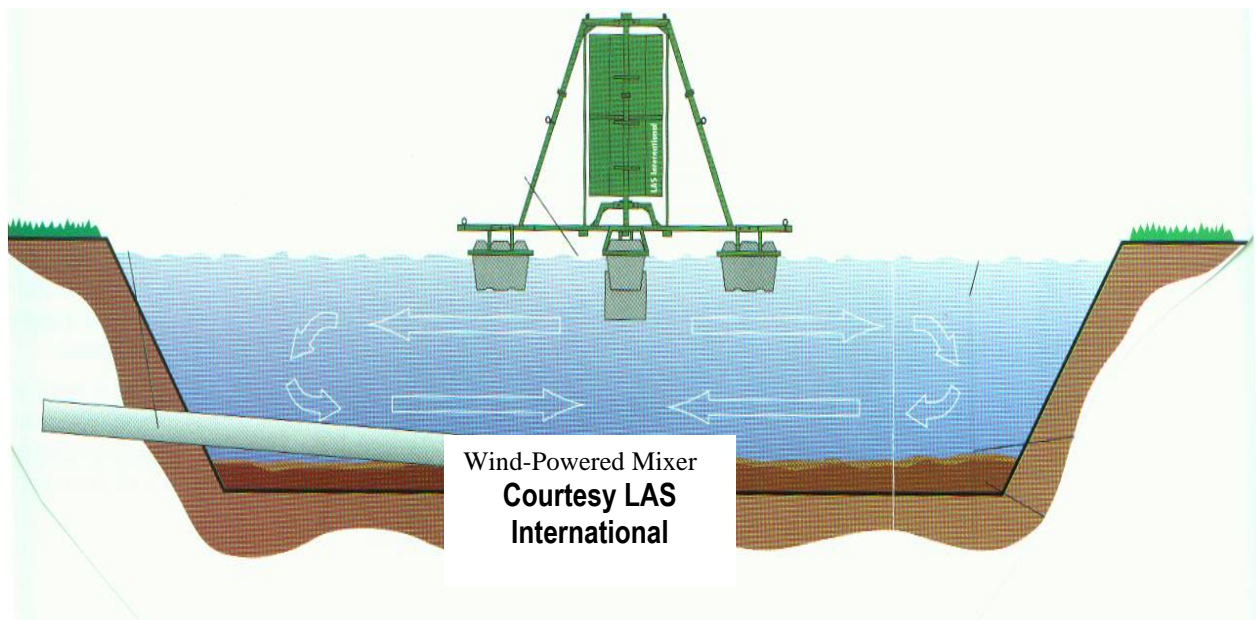

## **SOLAR POWERED MIXERS**

Solar powered mixers are finding some utilization in Montana to improve mixing and oxygen transfer in facultative lagoons. While the power source is free, the energy potential that can be taken from solar radiation and converted into electrical energy to power a mixing device is limited given the area of the solar panel that can be located on a floating mixer.

### **III. OPERATION AND MAINTENANCE**

Mechanical equipment requires operator attention and maintenance. Study the information provided by the manufacturer to be sure you are familiar with start-up, shut down, and operating recommendations and requirements. Positive displacement blowers are usually used in lagoon systems. An air relief system is provided on the blower so that air pressure can be gently applied to blow the water out of the airlines before full load is put to the aeration system. A blast of high-pressure air can destroy the underwater piping and/or the aerators. Watch blowers for overheating, for proper belt alignment and tension. Keep the air filter clean on a preventative maintenance schedule. Positive displacement blowers are sensitive to any restriction in the air supply and a dirty filter will make them overheat, as will inadequate lubrication. As with all mechanical equipment, lubricate with the manufacturer's recommended lubricant and on the specified interval. Make sure that the ventilation system is working in the blower building. High temperatures can damage electric motors very quickly.

A floating aspirating aerator should never be run with the propeller out of the water. In some models the bearing is water lubricated and will be destroyed by running dry. Watch current draw or motor temperature as indications of propeller fouling. If there is bucking, there may be vortexing, the mounting cables may need to be tightened, or rags may be hanging up on the propeller. Listen and watch for excessive vibration which may be due to loosened mountings or imbalance. A good preventative maintenance program will prevent crisis breakdowns and limit the possibility of discharge of poorly treated water.

Blowers and aerators are electrically powered with high voltage three-phase current. Unless you are a trained and competent electrician, leave hazardous electrical equipment to professionals. Your best guide to operation and maintenance of aeration equipment is the instructions and recommendations included in the manufacturer's operations and maintenance manual.

Successful aerated lagoon operators know the value of record keeping and laboratory work. In the Appendices of this manual you will find examples of log sheets devised and used by operators. A daily log records weather, color, odor, aerator function, run

times, air dispersion patterns, and other factors that the operator feels is important to note. The flow into and flow out of the system should be recorded as well as the level. Regular measurements of dissolved oxygen should be taken. Lagoon operators should note all these important parameters. Each year, these records will become more valuable in planning. Trend charts should be prepared to allow better understanding of how the system operates in response to differing conditions. Plotting flow, influent and effluent, BOD<sub>5</sub> and total suspended solids (TSS) values, nutrients in the effluent, fecal coliforms, dissolved oxygen, and other factors against time on a trend chart can be very useful in predicting the operation of a lagoon system. It can be used to vary the operation of the aerators and potentially save energy. The information can be used by new operators and could show someone how a system reacts to seasonal changes in the weather. It can alert system owners that an upgrade may be necessary if effluent values are deteriorating.

Sludge will build up rapidly in partially mixed aerated lagoons in comparison to facultative lagoon systems. Operators should periodically measure sludge depths in each of the lagoon cells, using a grid to establish position of sludge deposits. A record should be maintained on the sludge accumulations and the depths should be rechecked, roughly every five years. When the level of sludge in the lagoon reaches 18 inches the sludge should be removed. Failure to remove the sludge can cause the system to violate the discharge parameters. Sludge will add nutrients and may add solids to the water column and be discharged. The DEQ or the Montana Rural Water Systems can assist with sludge monitoring. For safety reasons, an operator should not do the work alone.

Refer to Section II of the previous chapter on facultative lagoons for general plant maintenance recommendations. The items listed there also apply to aerated facilities.

## **DISSOLVED OXYGEN**

A dissolved oxygen meter or test kit should be available and regularly used to be sure that proper DO levels are present. If less than 1 mg/l of oxygen is present, the aerobic bacterial population will start to die, and treatment will suffer. If an excessively high DO is maintained, the suspended solids may become difficult to settle and a high effluent suspended solid may result. Sampling for DO should be done with great care. (See Chapter 9 on sampling). As DO can vary considerably during the day and night because of algae and bacterial respiration, it is best to sample at the same location, the same depth, and at the same time of day to have consistent comparisons.

There are two methods of testing for dissolved oxygen including the Modified Winkler method, which is a chemical test, and the use of an electronic DO meter. There are compact kits available that simplify the Winkler method into an easily run field test, or it may be performed as a laboratory analysis. The DO meters utilize a membrane probe with an electronic instrument. Some are designed for use as handheld with field probes that can be inserted into the pond or flowing stream. Plants with laboratory facilities may have a bench type meter which will require bringing a sample into the lab. The meters



are quite easily calibrated and should be calibrated before each use (daily) to be certain results are correct.

Spot checks of DO levels in each of the lagoon cells as well as checks at various depth levels should be taken on an occasional basis. This information will help the operator know if the oxygen is being adequately dispersed and that sufficient mixing is being provided.

A pH instrument is also needed to check levels in the lagoon cell. While pH levels may vary from 6 to 9, levels above 9 may indicate an algae bloom (and a problem!). Some aerated lagoon plants will have a full laboratory, while others may send samples to a commercial lab for BOD and suspended solids tests. A good laboratory test schedule is necessary for an efficient system operation.

## CHAPTER 6

### I. DISINFECTION

Disinfection is a process or procedure in which pathogenic bacteria and viruses are destroyed or inactivated. *Pathogenic* is the term used to describe bacteria, viruses, or other microorganisms that cause disease. There are many varieties of bacteria that can cause disease and it is a very difficult task for the microbiologist to identify them all. So, instead of trying to find the actual pathogenic bacteria, another easily identified group of bacteria is used. This bacterial group is the coliform group.

Coliform bacteria are present in fecal waste from warm-blooded animals, including man, but may also be derived from other natural sources. A coliform test then identifies if there is a possible contamination from fecal waste. Some coliform-type bacteria come from sources other than fecal waste. So, to be more specific, a variation of the coliform test will determine only those bacteria that have fecal waste as their host source. This is the fecal coliform test.

Millions of both pathogenic and non-pathogenic bacteria are present in raw sewage. While conventional secondary treatment processes will reduce bacterial concentrations, disinfection of the treated effluent stream may still be necessary. Wastewater discharge permits typically require a maximum limit of fecal coliform in the discharge (generally determined instream after dilution):

- 126 organisms per 100 milliliters in the summer, and
- 256 organisms per 100 milliliters in the winter.

In other words, the regulatory agencies have determined that a concentration of coliform organisms per 100 milliliters listed above is a level that makes the water safe for recreational use. The DEQ establishes coliform limits in the Montana Pollutant Discharge Elimination System (MPDES) discharge permit specific to each stream receiving the treated wastewater. In many cases, DEQ does not require wastewater disinfection during the winter months due to the low potential for contact between recreational users and the receiving waters.

Historically, chlorination is the primary method of disinfection for wastewater in Montana. Ultraviolet light disinfection equipment is being used more frequently due to the safety and environmental benefits associated with the equipment. Both methods have certain advantages and disadvantages.

## II. METHODS TO DISINFECT WASTEWATER

### CHLORINATION

There are two principal methods of adding chlorine to water:

- gas chlorination, and
- hypochlorination using liquid solutions of either calcium or sodium hypochlorite.

A third less frequently used method uses tablets of calcium hypochlorite.

### GAS CHLORINATION

Chlorine gas is supplied in pressurized cylinders in liquid form much the same as propane. At normal room temperatures the cylinders have about 90 psi of pressure. Chlorine gas is very dangerous and poisonous, and it must be handled and used with great care. The usual method of feeding chlorine is with a vacuum ejector and pressure regulating controller (the chlorinator) that mounts directly on the chlorine cylinder. A stream of pressured water flows through the ejector and draws the vacuum. The chlorine gas is pulled into the stream of ejector water which is then fed into the main wastewater flow. A valve in the chlorinator opens only if vacuum is present. As the entire system operates under vacuum, no chlorine can leak. Chlorine dosage is controlled by a small needle type valve, or rotameter. The flow of chlorine is shown by a ball floating within a glass tube. Operators using gas chlorination should receive "hands-on" training at their site.

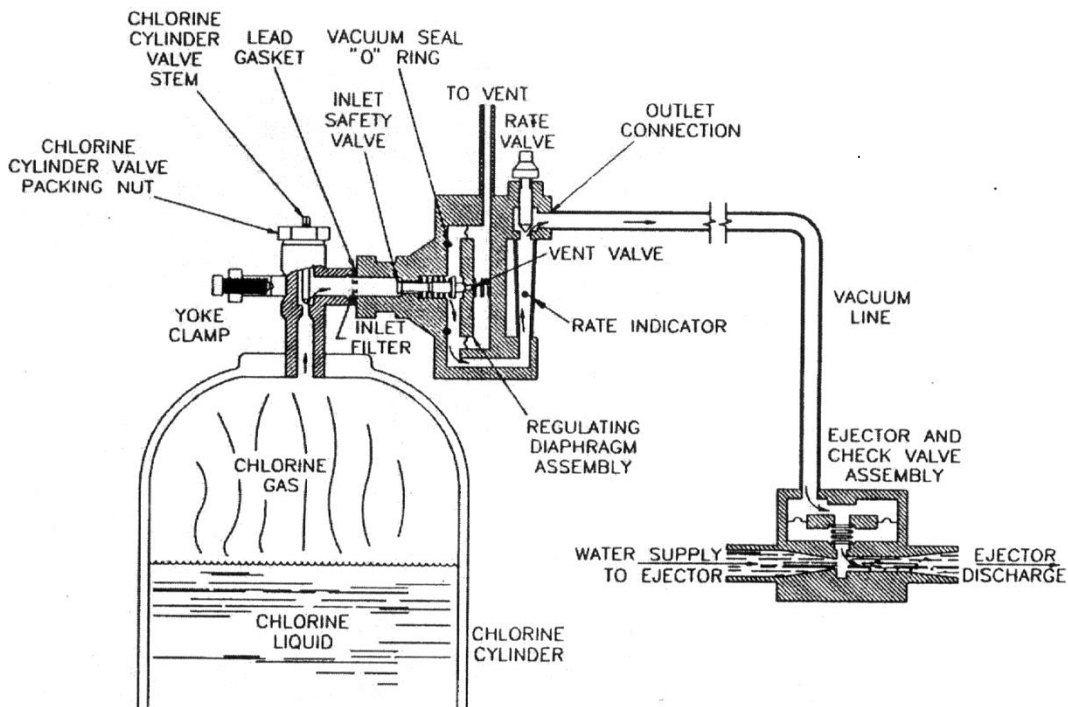

**Gas Chlorinator Assembly**

## HYPOCHLORINATION

Chlorine can also be obtained from sodium hypochlorite solutions. A common hypochlorite is household bleach, marketed under the trade names of Clorox, Purex, etc. The bleach has a strength of about 5.25 percent available chlorine. Chemical solutions are also available from chemical supply companies which contain 12-14 percent available chlorine. For disinfection, the hypochlorite is usually diluted (but can be used full strength) and fed to the wastewater with a small metering pump. Commercial grade chlorine should be used for wastewater disinfection rather than household bleaches.

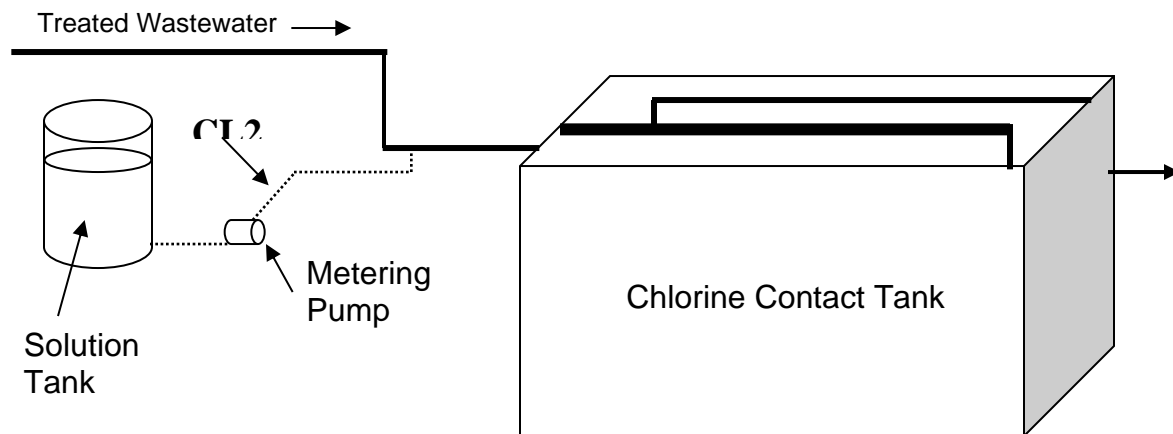

## HYPOCHLORINATION SYSTEM

Chlorine can also be obtained from calcium hypochlorite. Calcium hypochlorite is a solid white substance containing 65 percent available chlorine. It is available in a granular form that can be dissolved in water to make a solution. The solution is fed by a metering pump in the same manner as sodium hypochlorite. It is also available in large compressed tablets. The tablets can be put into a plastic holder and feeder where they slowly dissolve, releasing chlorine to the wastewater stream. This method of chlorination would make control of the chlorine concentration difficult.

## CHLORINE CONTACT BASINS

Chlorine does not kill instantaneously, so a contact time is required to produce the required disinfection. A contact time of 15 minutes at peak hourly flow is usually used for sizing contact basins. Contact basins constructed of concrete with serpentine or baffled channels are used to establish good plug flow conditions needed for effective contact time between the chlorine and the wastewater. Very turbulent mixing is needed at the point where the chlorine is injected into the wastewater flow stream. Usually two contact tanks are constructed so one may be bypassed, taken out of service and cleaned.

Chlorination will reduce the coliform count, but if the effluent contains algae, there is a possibility of killing the algae cells also. Dead algae increase the BOD. The chlorine concentration must be closely controlled under these conditions. The chlorine residual is limited in all discharges to 0.1 mg/l. In certain waters where toxicity is a problem, a lower limit will be set.

## DECHLORINATION

Residual chlorine and chlorine compounds can be toxic to aquatic organisms found in streams receiving treated wastewater. The DEQ will evaluate the available flow in the stream and set chlorine levels accordingly to protect downstream plant and animal life. If a community has a low fecal coliform limit and a low residual chlorine limit in their discharge permit, the use of dechlorination equipment may become necessary. Sulfur dioxide is a gas commonly used to *dechlorinate* wastewater, fed into the chlorinated waste stream with equipment similar to gas chlorination equipment. With good mixing, the dechlorination process occurs almost instantaneously therefore contact time is not needed. Monitoring equipment that continuously measures chlorine residual may be necessary to properly establish the required dosage level of chemicals used in the dechlorination process.

## SAFETY CONSIDERATIONS

Chlorine in all forms is a hazardous substance although gas chlorine requires special handling. Chlorine gas is heavier than air and will collect in low areas. Chlorination equipment should be housed in structures constructed specifically for this purpose and must have alarms to detect leaks. Operators utilizing gas chlorine should be well trained on how to properly use the equipment and protect themselves from exposure. Self-contained breathing apparatus (SCBA) must be available and used by the operator when fixing a leak. **Caution: Do not spray water on a leaking chlorine cylinder because the water will make the hole on the cylinder larger.** For more routine tasks, personal protection gear including rubber gloves, and face shields are a must. More information on safety precautions is included in Chapter 8 of this manual.

## ULTRAVIOLET LIGHT

Bacteria and viruses can also be killed by exposure to high intensity ultraviolet (UV) light. The light disinfects the wastewater by altering the DNA of the microorganisms so they can no longer reproduce. Wastewater (or drinking water) is passed under pressure through a chamber containing ultraviolet lamps. The lamps are enclosed in quartz jackets to protect them from direct water contact. The lamps are similar to fluorescent lamps and are usually 48 inches long and spaced about 3 to 4 inches apart. The number of lamps required depends upon the flow rate and UV dosage needed to achieve a required rate of bacterial reduction. Typically, two units must be provided to allow for process reliability and redundancy.

Another design of UV equipment uses banks of ultraviolet lamps in quartz jackets immersed directly into a concrete channel in an open channel flow configuration, as

shown in the following drawing. Usually the equipment will be enclosed in a small building.

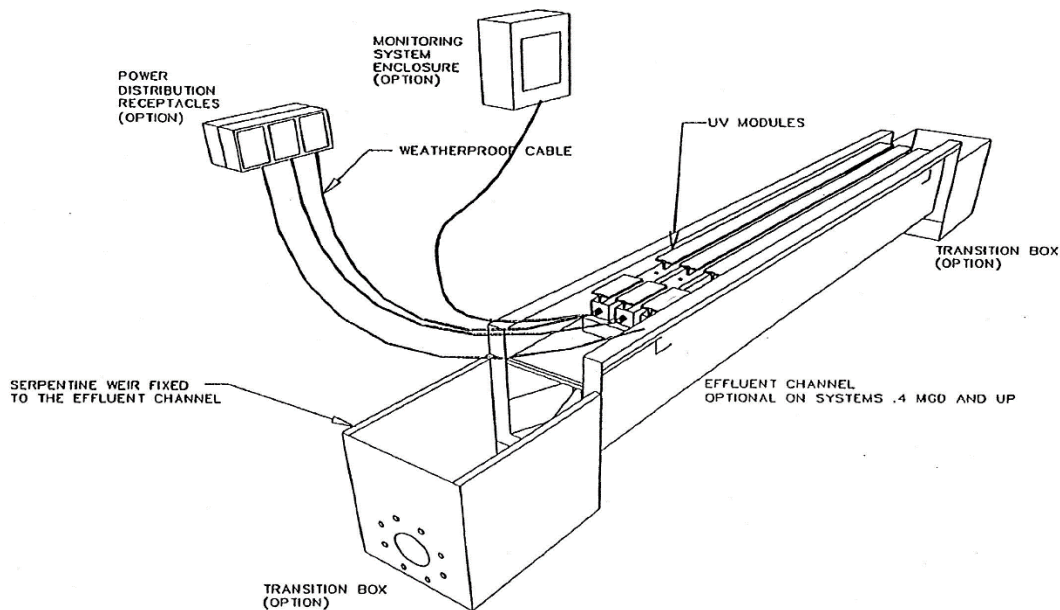

*Open Channel UV Disinfection System*

## **OPEN CHANNEL UV DISINFECTION SYSTEM**

Ultraviolet disinfection systems leave no residual that can be tested. To evaluate the performance of the UV equipment, it is necessary to run a test for coliforms. For control purposes, instruments show light intensity and give a signal if light intensity is too low. The efficiency of UV disinfection is affected by turbidity (cloudiness) of the water and the buildup of scale on the tubes. While algae can reduce the overall performance of the UV process, the algae are not appreciably affected under the usual dosage necessary to inactivate bacteria.

Operational requirements of the system include checking the process equipment, cleaning the tubes, and replacing the bulbs. Bulb life is approximately 10,000 to 15,000 hours. Cleaning requires removal of the tubes or banks of tubes and cleaning with a de-scaling solution such as Lime-a-Way. The tubes also require power, generally provided through a 120-volt power supply.

Water that has been disinfected by the UV process will not be toxic to instream aquatic organisms. Chlorinated compounds normally generated as a byproduct of chlorination processes are not present. While the process is inherently safer than chlorine disinfection, UV light can be damaging to eyes and the operator must wear properly shielded eyewear. The tubes may become hot and cause burns.

## **OTHER DISINFECTION METHODS**

Other ways to disinfect wastewater are possible but are not discussed in this manual because they are not used in Montana. Ozone has been used for wastewater

disinfection. Other chemicals, including chemical substances with chlorine as a component, are used for disinfection.

## CHAPTER 7

### I. CONVEYANCE SYSTEMS

Wastewater collection systems, or sanitary sewers, are used to connect sources of wastewater, homes, commercial establishments, and industries to wastewater treatment plants (WWTP). The components needed to collect, pump, and discharge wastewater to the treatment facility is called the conveyance system.

#### COLLECTION SYSTEMS

Collection systems consist of a series of connected underground pipes and/or pumping stations. The most common type of collection system is a gravity flow system that uses pipes laid on a declining gradient to allow flow velocities of about 2 feet per second to keep wastes and solid material in suspension as the wastewater flows through the pipe. Other types of collection systems, such as septic tank effluent pumping (STEP), rely on a series of small pumps attached to the piping system to convey the wastes to the wastewater treatment plant. Gravity system pipes gradually get deeper into the ground until it becomes difficult to install the pipes, while STEP systems can follow the contours of the area.

Collection systems are made up of pipes of many sizes. Smaller sections are attached to the initial wastewater sources and the sizes increase as more trunk lines are attached to a main trunk. Manholes are concrete structures located at changes in pipe grade or direction or will be regularly spaced to allow access to the upstream or downstream pipe sections for maintenance. Pumping stations, or lift stations, may be used in gravity flow systems to raise the wastewater up so that it can flow downward again to the next lift station or treatment plant.

Pipes can be made of different materials such as clay, concrete, iron, or plastic materials. The materials should resist corrosion since wastewater can contain or generate dangerous gases or chemicals that can cause the pipes to break down. Pipe systems in poor condition can leak, allowing infiltration by groundwater into the wastewater or allowing wastewater to exfiltrate into the groundwater. Either situation will cause problems either at the WWTP or in groundwater, potentially affecting the environment and/or public health.

Other sources of water into collection systems include storm water and illegal *inflow* sources. Storm water collection systems gather excess rainwater and snowmelt and carry it to surface water outlets or treatment facilities or combine it with sanitary sewers. When storm drains are attached to sanitary sewers, the extra water can wreak havoc in the treatment plants. Combined sewers with storm and domestic wastewater should be separated to prevent problems with collecting and treating domestic wastes. Illegal inflow sources include roof drains from buildings or sump pumps from basements.

The amount of wastewater treated in a WWTP can be measured by checking flows in various trunks of the collection system, in lift stations, and at the wastewater treatment



facility. Often, infiltration and inflow (I/I) sources can be identified and removed. The overall volume of I/I in the total wastewater flow to a WWTP can be significant and can increase the cost of treatment. Short-term flow events causing large amounts of I/I can drastically reduce performance of the treatment system by flushing the beneficial microorganisms out into the effluent.

Maintenance of a collection system includes many activities. Flushing the lines will help clear blockages and debris. Using an in-pipe camera system will document the interior condition of pipes and connections, aiding in the repair and replacement of bad sections of the system. **Operators must apply all appropriate safety measures when working on the system, monitoring discharges from various sources, and maintaining the pumping stations.**

**Note: Collection systems and lift stations are all confined spaces. Before entering areas to perform work safety precautions and confined space safety permit requirements must be met.** Call the Safety Bureau of the Department of Labor and Industry (406-444-6401) for more information.

## II. LIFT STATIONS, PUMPS AND MOTORS

Lift stations are necessary in a wastewater collection system to collect wastewater at low areas in a community and convey the water to the treatment system or lift the fluid up into a gravity line. Lift stations require significant operation and maintenance and should be avoided in the design of a system, if possible. Generally, a lift station will consist of a wet well, pumps, controls, valves, and discharge piping or force main. The force main carries the pumped fluid downstream to the treatment plant or to another sewer main. The pumps used to convey the wastewater are usually centrifugal pumps designed to carry solids without clogging. The wet well of a lift station allows wastewater to collect between pumping cycles and should be sized large enough to prevent excessive cycling (off/on operation) of the pumps. Lift stations should have at least two pumps and each pump must be capable of passing the maximum expected flow in the system.

Controls that activate the pumps set the “on” level, the “off” level, alarm conditions, and levels which would activate the second pump. The control system should also alternate operation between the two pumps, so each pump and motor have about the same time of actual usage. Pump stations where the pumps and motors located in the wet well are called submersible pump stations. Pump stations where the pumps are located adjacent to the wet well in a separate structure are called dry pit pump stations or wet well-dry well pump stations. Pump stations may be custom built on site using concrete structures or may be delivered to the site as a “package” lift station.

The pumps discharge into the force main with an isolation valve and a check valve used in proximity to the pump equipment. The isolation valve is used to allow removal of the pump yet keep the operating pump in service. The pumps must provide sufficient energy to raise the fluid to the final discharge point, overcome the frictional resistance in the piping or valves and to provide velocity to the fluid. The sum of these energy needs

is called the total dynamic head of the system. The check valve prevents flow in the force main from flowing backwards into the wet well when the pumps are off. The force main is a pressurized pipe conduit which carries the wastewater to the delivery point in the system. Force mains must be at least 4 inches in diameter and are sized to ensure that the flow velocity in the pipe is at least 2.0 feet per second, which is the minimum velocity needed to keep the wastewater solids in suspension. Force mains should be buried at least 6.0 feet deep to prevent freezing and should have air and vacuum relief valves at high points in the main, other than the discharge point. Long force mains or force mains with much lift may create conditions for water hammer – a strong

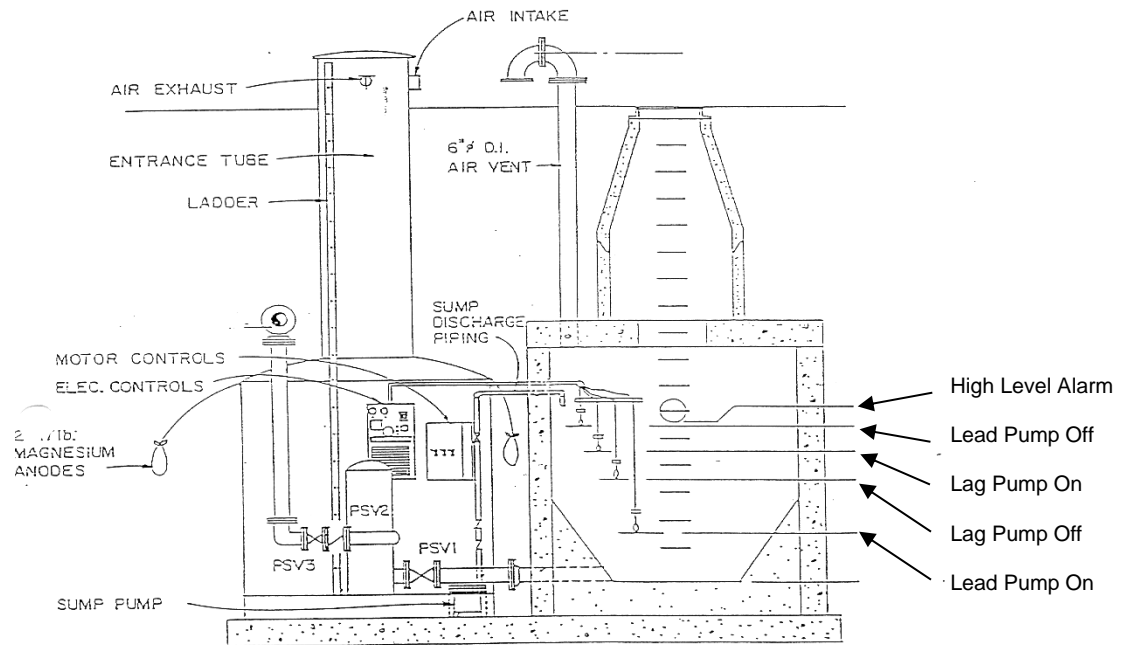

*Package Lift Station*

pressure wave in the liquid which occurs with an abrupt change in flow rate, such as when a pump shuts off. Water hammer creates high pressure conditions which can damage piping components.

## **OPERATION AND MAINTENANCE**

Lift stations should be checked daily for proper operation. Pumps should be running smoothly and without cavitation. Cavitation is a low-pressure condition that occurs near the pump impeller where potentially damaging energy forces can be generated. Pump time recorded from hour meters. Controls and alarms should be functioning properly. Lift stations should have visual and audible alarms that will alert someone as to an adverse situation. Telemetered or radio alarms may be necessary for remote lift stations. Any high-level conditions should be investigated for cause. Wet wells will require periodic cleaning and removal of large objects which cannot be pumped. Wet well and dry pits are confined spaces and all appropriate safety precautions must be observed when entering these areas. Ancillary equipment on a lift station, such as blowers or sump pumps, could be critically important to the safety of the system and

should always be kept in good operating conditions. Most pump stations require a backup power supply such as an emergency generator to ensure that the pump station is functional during power outages. This equipment also must be kept in good operating condition, ready to use when the storm hits. Any off-site storage of power generation equipment must be in a location immediately accessible to the operator and the operator's backup person when it becomes necessary to use the equipment.

## PUMPS

Pumps are mechanical devices attached to electric motors or generators and are used to move liquids through the wastewater collection and treatment system. Pumps are used within treatment plants to move wastewater from one basin to another, to discharge treated effluent from the facility, to feed chemicals into system processes, and to move the collected and treated wastes, or solids, around and out of the facility.

Pumps generally fall into two categories: centrifugal and displacement. However, screw pumps and airlift pumps are also frequently used. Centrifugal pumps use the dynamic force generated by a motor to spin an impeller that draws liquid into the eye of the pump and forces the liquid out the discharge port. The spinning impeller throws the wastewater away, while drawing more wastewater into the pump. Displacement pumps use motors to create a reciprocating back-and-forth pump shaft motion or rotating pump shaft to displace one volume of liquid with another volume inside the pump chambers.

Centrifugal pumps spin at high speeds and are used to move high volumes of wastewater that contain low concentrations of solid material. Displacement pumps are used to move heavier, high solids content material at smaller pumping rates.

Centrifugal pumps will be found in lift stations to pump raw wastewater and in other areas of the treatment facility to convey the high volumes of wastewater from basin to basin or to the effluent. They will also be used to pump out sumps.



*Courtesy of Gorman-Rupp*

Displacement pumps are used to move collected scum, solids, and to feed chemicals. These pumps generate high pressures and should **never** be operated against a closed discharge valve.

Centrifugal pumps may be called: end suction, split case, and vertical turbine pumps. Special types of pumps are called airlift and pneumatic ejector pumps. Reciprocating displacement pumps may be piston or diaphragm, while rotary displacement pumps are peristaltic, progressive cavity, and multiple gear-lobe pumps.

Components of a centrifugal pump are: Motor, shaft, packing or seal, impeller, and volute, with suction and discharge valves and sometimes a check valve to prevent

backflow. Displacement pump components will vary greatly depending on type, using flexible diaphragms, pistons, check balls, rotating cams, etc., but include a motor, shaft, packing or seal, high-pressure shutdown switches and isolation valves.

Maintenance of pumps includes checking and replacing lubricants, checking packing condition, adjusting the packing to allow the lubricating fluid to drip slowly, pumping capacity, heat, vibration and alignment of pump and motor, condition of seals, and worn and broken parts.

### **III. MOTORS & ELECTRICITY**

Electricity is used to drive motors that in turn drive other types of mechanical equipment in wastewater systems. Power supplies for the treatment system must be reliable and, in critical areas of the system, should have a backup generator to provide emergency power.

Electric motors are designed to rotate when electrical current is applied across the poles of the motor. Some motors are two-phase, while three-phase motors are commonly used in wastewater systems. Motors are rated in horsepower, which is a measurement of the work output available to move water or do other types of work. Motors are attached to pump shafts, providing the pumping systems to move liquids and solids in wastewater treatment facilities.

Electricity is a source of power derived from the flow of electrons. When an electrical difference, or electromotive force, exists between two poles or ends of an electrical system, electrons will flow from one pole to the other. This is much like the flow of water from a high point to a low point.

#### **ELECTRICAL FLOW**

Electrical flow, or *current*, comes in two forms, depending on how it was generated or transmitted to the point-of-use: direct current (DC) and alternating current (AC). In DC systems, the flow of electrons is always in a single direction, like that in a car battery from the positive pole to the negative pole. In AC current systems, the flow of electrons alternates direction and is typically 60 complete cycles of alternation per second. The term commonly used for cycles per second is Hertz (Hz). AC current is used to run lighting systems, run motors and pumps, and is the type we more commonly use in our everyday life.

Electrical circuits may be open or closed. An open circuit is like having a light switch in the off position since electrons can't flow through an open switch. When the switch is closed, and the switch points make contact, electricity can now flow to cause a light bulb to glow or run an appliance or motor.

Exposed wires and live, or closed, circuits can create dangerous conditions when operators are working on equipment. Control devices such as circuit breakers must be locked out, or locked open, so that maintenance activities can be accomplished safely.

A tag should be placed on a locked-out control device to indicate that the breaker is off for a specific purpose and should not be changed.

## CHAPTER 8

### I. SAFETY

***All employees working around a wastewater treatment system should be aware of the hazards that exist there. These hazards may not be readily apparent, but without constant vigilance someone can be hurt or even lose their life. The hazards listed in this chapter may not include every hazard found in a wastewater treatment system. Make a close inspection of your facility and list all the possibilities for an accident that you can find. Practice good personal hygiene whenever working around wastewater. Use the right tool for the right job. Back injuries are one of the most frequent injuries suffered by wastewater plant personnel. Lift things properly and get help when needed. No smoking on the job except where permitted. Hold regular safety meetings with other plant staff and discuss hazards associated with the job and how best to avoid them. Keep notes of the meeting and distribute them to the staff.***

### DROWNING

Water hazards are always a problem at wastewater facilities. Working around the sloping banks of a lagoon is inherently dangerous. If you need to venture down the slope toward the water, put on a life jacket. It is possible to slip, fall into the water with serious results if the operator hits his head and is knocked unconscious. Exposed liners without a soil cover are particularly slippery. Use a hand line to assist in returning up the

slope. If it is necessary to check floating aerators using a boat, always put on a life jacket. It is very easy to tip a boat and take an unpleasant bath.

### CAUTION

1. WEAR APPROVED FLOATATION DEVICES WHEN WORKING OVER WATER SURFACE.
2. DISCONNECT ALL ELECTRICAL POWER BEFORE SERVICING AERATORS ON FLOATATION EQUIPMENT.
3. PONTOON AND FRAME SURFACES ARE SLIPPERY WHEN WET.
4. NO PERSONNEL ALLOWED ON FLOATATION EQUIPMENT WHEN THE AERATORS ARE OPERATING.
5. READ AND FOLLOW SAFETY PRECAUTIONS LISTED IN TROUBLESHOOTING SECTION OF OPERATING AND MAINTENANCE MANUAL.

— SAFETY IS YOUR RESPONSIBILITY —

Hypothermia can kill quickly in cold weather. **Do not work alone when unsafe situations are present!**

***Ice is an ever-present hazard during cold weather. The winter temperatures and snow present a hazard that the operator must constantly be aware of. Ice on the pond is readily noticeable but watch out for icy conditions all around the plant site. Falls are one of the most common accidents. Venturing upon an ice-covered lagoon presents a serious hazard and should never be attempted.***

***Life jackets, a boat, rope, and float ring must be available at any lagoon facility.***

## CHEMICALS

If gas chlorine is used, special safety practices must be observed. Chlorine is very poisonous. All chlorine cylinders (especially ones in use) must be provided with a safety chain to prevent them from falling. A self-contained breathing apparatus (SCBA) must be available and ready for use. Frequently check the air supply in the SCBA cylinder and replace when it gets low. A fully charged spare cylinder must be on site. Be sure that all employees know how to put the SCBA on and how to use it. The SCBA must be fit tested for the individuals who are to use the unit.

The presence of chlorine must be reported to local officials. The fire department should be aware that chlorine is used at your facility. It is wise to work with your local fire department for backup in case of an emergency. Develop an emergency response program with local officials.

Calcium hypochlorite is a hazardous material. It can react rapidly and violently if it comes in contact with combustible material such as oil, sawdust, paper, etc. It should be kept in its tightly closed container. Use a dedicated scoop and measure. Personal protective gear such as gloves, respirator, and eye protection are a must when working around the various forms of chlorine. Sodium hypochlorite is not as hazardous as other chlorine forms, but still must be handled with respect. It is highly caustic, and the concentrated form can burn the skin and destroy eyesight.

Other chemicals should be handled very carefully. Pesticides and herbicides are hazardous and must be used and handled strictly according to the instructions on the label. Never dispose of chemicals in your sewer or lagoon system. This would be a violation of water quality laws and may destroy the biological organisms in your treatment plant, resulting in poor system performance.

Chemicals should always be handled with eye protection and with rubber gloves.  
**PROTECT YOURSELF.**

## ELECTRICAL

Even low voltage of electricity can *kill*. Electricity around water is especially hazardous. Operators should not work on electrical equipment unless specifically trained. Poking a screwdriver into an electrical panel is deadly! If there is an electrical problem requiring attention, get a qualified electrician to take care of it. Whenever a pump, aerator, or other electrically powered equipment is being worked on, open the circuit breaker, tag it and lock it as part of your Lock out Tagout (LOTO) Procedures. Include name, date, and reason for lock out.

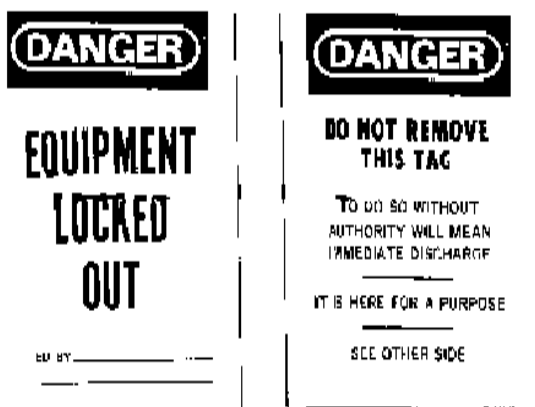

## CONFINED SPACES

Probably the deadliest of all hazards in the wastewater industry is the confined space. Usually this means a manhole or a wet well. Any time an employee goes into a confined space, the individual must be very careful to check for oxygen level and for the presence of deadly gases. Test for oxygen first, flammable gases second, and toxic gases last. Workers should never work alone when entering confined spaces. On too many occasions, one person has passed out at the bottom of a space, only to have his buddy also die trying to rescue him. Gases can accumulate in these locations. The oxygen concentration in the air may get so low (less than 19 percent) that it will not support life. Carbon monoxide or hydrogen sulfide, both deadly gases, can accumulate in any confined space. Just because you have been down there before without incident, does not mean that it will be safe the next time. **Never assume a confined space is safe.**

***There are some important rules to know and understand to assure safety in trenching. Call the Safety Bureau of the Department of Labor and Industry (406-444-6401) to obtain the rules for workers who are engaged in trenching activities.***

## LIFT STATIONS

Lift stations present hazards that employees should always be aware of when entering. A lift station is a confined space and the statements above apply. A lift station that can be entered must have a ventilation fan which automatically turns on when the manway lid is opened. Let the fan ventilate for a few minutes before entering. Be sure that the cover is completely back and secured. Ladders are easy to slip on, so make sure you have secure footing on each rung. Be very careful of electrical wiring and equipment as even 120V can be deadly in a wet area. General safety practices to observe around pumping equipment include the following:

- Keep guards and shields in place
- Do not remove labels and tags during maintenance
- Pumps may be hot, approach them cautiously
- Do not pump against a closed valve or with a plugged suction line
- Use lifting equipment designed for the job
- Ensure power is OFF when working on the pump
- Use your O&M Manual
- Watch loose clothing and long hair around equipment
- Know what to do before working on a pump or motor

Entrance into a wet well of a lift station should be avoided if possible and operators should attempt to perform all maintenance work from above. If necessary, to enter a wet well, the space must be adequately ventilated, and the atmosphere tested before entering. Use confined space procedures. Use a removable ladder for access and do not trust the manhole steps that may have been installed in the original construction of the wet well. Access should be made with the appropriate safety harness on the



individual entering the space including the necessary means to lift the individual from the space.

Any time an employee is performing work where a possible hazard may be present, use the buddy system. Have another employee present to help or to get help.

## CHAPTER 9

### I. SAMPLING

**Taking samples is one of the operator's most important duties. A correctly taken sample is necessary so that the analysis will accurately represent how the operation is performing. The analysis of a sample, no matter how carefully and precisely performed, will reflect both good and bad sampling procedures. The results from the sampling and testing are reported to the regulatory agency on Discharge Monitoring Report (DMRs). If improperly taken samples are represented as being a true picture of the plant operation, the operator may be held responsible for misrepresentation of facts and subject to criminal penalties.**

It is very important that the operator take the time and effort to be certain that the samples taken are truly representing the conditions present in the treatment system.

Here are some rules that should be followed:

1. Always take samples from a well-mixed flowing stream. Samples taken from a quiet zone will probably be lower in suspended solids and not representative.
2. Always use a clean sample bottle. Any dirt in a sample bottle or sampler may make your sample look worse.
3. Some samples must be tested immediately after being taken. Residual chlorine, temperature, pH and dissolved oxygen should be tested immediately. If samples are to be sent to a laboratory, contact the lab for sampling instructions.
4. Some samples may be sent to another location for laboratory testing. These should be immediately placed in a refrigerator or packed in ice for shipping. They must be kept cold (6°C). The laboratory can provide specific instructions on preservation and shipping of samples.
5. A sample tag should be placed on the sample container which lists the type of sample, where it was taken, the date and time of sampling and name of the person taking the sample. This information should also be recorded on a Chain-of-Custody (COC) form.
6. Samples of the discharge must be taken after all steps in the treatment, with one exception – samples taken for effluent BOD<sub>5</sub> should be taken before chlorine is added.
7. Samples for dissolved oxygen (DO) must be taken with a sampler that does not allow air entrainment. DO can be measured instantaneously at the site using a DO meter.

There are two different types of samples:

- (1) Grab sample, which is a single sample taken once at one spot.
- (2) A composite sample is intended to represent the conditions more closely over a set period of time, usually 24 hours. A composite sample properly taken would be collected continuously with the amount of sampling corresponding to the flow rate. A grab sample taken every four hours then mixed together is often used to approximate the more ideal composite sample conditions. Special samplers using a small withdrawal pump that samples in proportion to the flow rate are available for more precise composite samples.

The following table discusses various procedures for sampling wastewater.

**SAMPLING TABLE**

Test	SAMPLE TYPE	SAMPLING DEVICE REQUIRED	SAMPLE PRESERVATION METHOD	SAMPLE HOLDING TIME (max)
pH	GRAB	NO SPECIAL	NOT PERMITTED	IMMEDIATE
CHLORINE RESIDUAL	GRAB	NO SPECIAL	NOT PERMITTED	IMMEDIATE
DISSOLVED OXYGEN	GRAB	NO SPECIAL	NOT PERMITTED	IMMEDIATE
BOD <sub>5</sub>	GRAB OR COMPOSITE	NO SPECIAL	KEEP AT 6°C(43°F) OR BELOW DO NOT FREEZE	48 HRS
TOTAL SUSPENDED SOLIDS	GRAB OR COMPOSITE	NO SPECIAL	KEEP AT 6°C (37°F) OR BELOW DO NOT FREEZE	48 HRS

For best results when obtaining a grab sample for dissolved oxygen, a special sampling bottle can be made which fills from the bottom and minimizes contact with air. The sample should not be agitated or remain in contact with air as either could cause a change in the dissolved oxygen content of the sample.

As discharge permits become more complex, specialized sampling procedures for various constituents become necessary. The laboratory that will perform the analysis of the sample is generally the best source of information regarding sample collection and preservation. Often the lab will provide the sample containers and preservatives needed for collection of the sample.

## CHAPTER 10

### I. FLOW MEASUREMENT

One of the items required on a Discharge Monitoring Report (DMR) is the flow rate. A means of measuring the influent and effluent flow should be provided at every wastewater treatment plant. Newer systems may have flow metering instruments which show instantaneous and totalized flow. Totalized flow is the total flow that passes through the meter over a known length of time. If flow metering instruments and recorders are being used, maintenance procedures as provided by the manufacturer should be observed. Meters should be calibrated using a primary flow measuring device, such as a weir, to maintain accuracy.

Lagoons often are equipped with a weir or flume type of flow measurement device. There are several different open channel flow measurement weirs and flumes. Devices such as a weir which measure flow directly are called primary measuring devices. A flume is a specially shaped open channel flow section usually including a converging section, throat, and diverging section. The flume creates a known hydraulic condition where the area of the flow stream can be measured to determine flow. Flumes work well for measuring the flow of raw sewage because they tend to be self-cleaning, without an accumulation of solids.

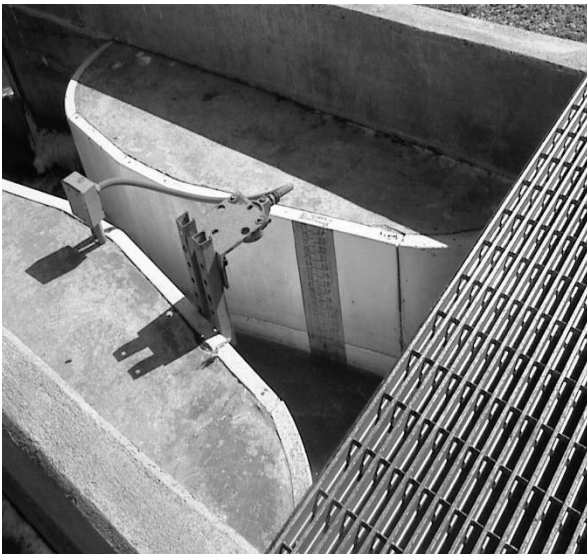

*Parshall Flume*

A weir is a dam, or a plate, placed across the flow channel with a notch in the plate. Water is dammed behind the plate and overflows at the V-notch. The notch may be one of several kinds. The more common are a 60° V-shaped notch, a 90° V-notch and rectangular notches. The bottom edge of the notch is called the *crest* and the level of the flowing water above the crest is referred to as the height or the head. The head measurement is in a chart for conversion to a flow rate. For most accurate results, the crest must be sharp edged, with a maximum width at the sharp edge of about 3/16 inch. Solids that accumulate on the crest of the weir should be removed to maintain accuracy.

The measurement of the water level behind the crest should be taken at enough distance behind the weir so that the falling level near the crest will not affect the reading. A distance of three times the expected head is required. A staff gauge should be mounted with the zero point exactly at the level of the weir crest.

Measuring flow with a rectangular weir is done in the same manner. A measurement of the depth of water flowing over the weir (the head) is taken and the flow at that depth is found from a table or reference curve. The depth measurement has a specific mathematical relationship with the type of weir and the weir tables calculate the flow based on a mathematical formula that applies to only one type of weir. Using a weir table for a

rectangular weir when you have a V-notch weir will provide considerable error in your flow rate determinations. Make sure you have the right table for your weir or flume!

A few simple rules govern the accuracy of the weir:

1. The weir plate should be plumb and level.
2. There should be no leaks around or under the plate.
3. There must be free flow conditions. The water should flow freely over the crest and be aerated. Water should not run down the face of the weir.
4. Both the crest and the sides of the weir opening should be sharp edged. Rectangular weirs that extend completely across a channel and have solid side walls are a special case that require special treatment for accuracy.
5. The point of measurement should be upstream at a distance of at least three times the maximum head expected.
6. The velocity of the water approaching the weir should be negligible. A still pond should exist above the weir.
7. The maximum head with accuracy for rectangular weirs is about one third the length of the crest opening.

General housekeeping maintenance is required. Trash and weeds should be kept clear of the weir. If sediment deposits behind the weir then the sediment should be periodically cleaned out. The zero point of the gauge should be periodically checked to see that it is accurate to the crest elevation of the weir plate.

**For low flows the V notch weir is the most accurate, with layout similar to that shown in the front and side views in the following drawings. For special conditions, other varieties of weirs are used. For a low flow accuracy where high flow conditions also occur, a compound weir can be used. It consists of a small narrow V notch at the point of a wider V notch weir.**

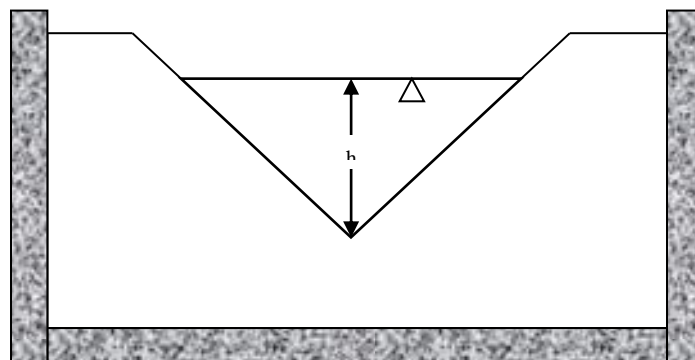

90 ° V-Notch

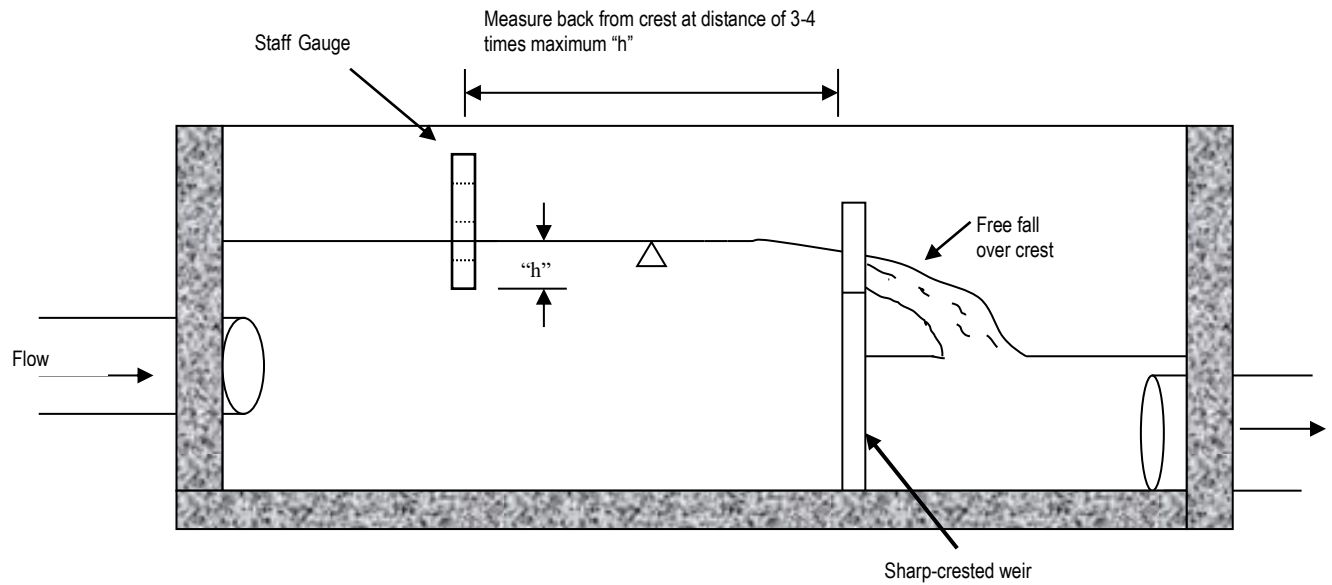

### Flow Measurement with a Weir

The following chart lists the water flow in gallons per minute for quarter inch increments for several common weir sizes. If your system is equipped with a Parshall or Palmer-Bowlus flume, a flow chart should be supplied by the manufacturer or design engineer.

**WEIR TABLE – FLOW RATE IN GALLONS PER MINUTE**

INCHES	60° V	90° V	12" RECT	18" RECT	24" RECT
.25			5.0	7.0	10.0
.50			13.0	19.0	26.0
.75			23.0	35.0	46.0
1.00	1.30	2.25	36.00	54.00	75.0
1.25	2.27	3.93	50.00	76.00	100.00
1.50	3.58	6.20	66.00	99.00	132.00
1.75	5.26	9.11	83.00	124.00	166.00
2.00	7.34	12.72	101.00	152.00	202.00
2.25	9.86	17.08	121.00	183.00	242.00
2.50	12.83	22.23	142.00	213.00	284.00
2.75	16.28	28.21	164.00	246.00	328.00
3.00	20.24	35.06	187.00	280.00	374.00
3.25	24.72	42.83	210.00	316.00	420.00
3.50	29.75	51.55	235.00	353.00	470.00
3.75	35.35	61.25	261.00	392.00	522.00
4.00	41.54	71.98	287.00	431.10	574.00
4.25	48.34	83.76	314.00	472.48	628.00
4.50	55.77	96.62	343.00	515.00	686.00
4.75	63.84	110.60	374.00	559.00	748.00
5.00	72.58	125.74	403.00	605.00	806.00
5.25	81.99	142.05	433.00	650.00	866.00
5.50	92.10	159.57	464.00	695.00	928.00
5.75	102.96	178.32	496.00	745.00	992.00
6.00	114.48	198.34	528.00	791.00	1050.00

## **OTHER WAYS TO MEASURE FLOW**

Often a treatment plant operator or consulting engineer needs to know what flows are into a treatment system yet may not have historical records to directly show what flows to the system have been. Many lagoons do not have any means to measure flow into the system even though current design standards now require influent flow measurement.

Often, lift stations can be used to estimate flow. If the output of the pumps and the number of hours that the pumps operate is known, an estimate of flow can be made. A drawdown test can be used to determine the output of the pumps in the pump station. In this test, the wet well volume is known and the time it takes to draw the wet well down is taken to determine pump flow volume over a known length of time. Manufacturer's information can also be helpful in determining the output of pumps in a pump station.

Water use records are another means of estimating flow into a sewage system. Typically, about 70 percent of the water used in a system in the winter months ends up in the sewer. If a sewer system picks up water from infiltration and inflow, using water use rates to estimate wastewater flows may underestimate actual flow.

If an upgrade to a wastewater system is being proposed, accurate flows are critical to the proper sizing and design of new facilities



## CHAPTER 11

### I. LAWS, REGULATIONS, PERMITS

It is important for the operator to be familiar with the laws, regulations, and permits that concern the operation of a lagoon wastewater system. The general law governing all wastewater discharges is the *Clean Water Act of 1972* and the amendments that have followed. The Act as passed by Congress is the basis for most state laws and regulations.

Montana has taken primacy for the enforcement of many federal laws, which means that the State of Montana is the responsible enforcement agency. If primacy for a given program by a state is not accepted, then enforcement would be by the Environmental Protection Agency.

The EPA has established National *Secondary Standards* which set the minimum acceptable level of treatment of wastewater. No discharges can exceed the limits set out in those standards. The EPA requires permits, testing, and reporting for all discharges. Discharges may also be required to meet state standards under the Montana Water Quality Act.

The ***Montana Water Quality Act*** (Act) establishes public policy to:

1. Conserve water by protecting, maintaining, and improving the quality and potability of water for public water supplies, wildlife, fish and aquatic life, agriculture, industry, recreation, and other beneficial uses.
2. Provide a comprehensive program for the prevention, abatement, and control of water pollution.

The Montana Water Quality Act gives authority to the State Board of Environmental Review and to the Department of Environmental Quality to adopt rules and regulations. The Act requires a classification of state waters based on beneficial uses and sets standards for purity as needed to maintain or support beneficial uses. These classifications must be reviewed every three years.

The Act requires “nondegradation” of state waters so that the existing quality of waters will not be lowered. Any new or enlarged source of possible pollution must provide a degree of treatment to maintain the quality of the receiving stream. Any new or enlarged discharge must not appreciably change the characteristics of the receiving water. Water quality is protected by limiting the annual pollutant loads including: BOD<sub>5</sub>, total suspended solids, total nitrogen, and total phosphorus. These limits are established in your discharge permits.

**Each point source discharge must be issued a permit to discharge.** The permit will give effluent limitations, testing, and reporting requirements. The permit is valid for five years at which time an application for renewal must be made 180 days before expiration.

Most discharges from small lagoon systems will be limited to a 30-day average of 30 mg/l for BOD<sub>5</sub>. Total suspended solids are limited to 100 mg/l as a 30-day average. The pH is to be between 6.0 and 9.0. In addition, the 30-day BOD<sub>5</sub> removal percentage must be at least 85 percent and TSS removal percentage must be at least 65 percent, depending on the receiving stream. The permit will list the self-monitoring requirements, the frequency of sampling, and type of analysis to be performed.

If a lagoon discharges into high quality water, or into a stream with relatively low flow compared to the waste stream, other restrictions may apply as necessary to maintain the instream water quality. Several materials can be quite toxic to fish or aquatic life. Among these are ammonia, chlorine, and heavy metals. Toxicity is rated as acute or chronic and applies to the mixing zone. Acute standards cannot be exceeded in the mixing zone. Fecal coliform is restricted in many discharges during the months when swimming or other activities might involve public contact with the water. The impact of each discharge upon the receiving water is evaluated by DEQ in setting permit limits.

## **MIXING ZONE**

The mixing zone is a portion of the state waters receiving discharges from wastewater treatment plants where water quality standards can be temporarily exceeded, except for acute toxicity standards.

For DEQ to carry out its mandate of protection of the state's waters, it is necessary to know the location, quantity, and quality of each point source discharge. This is accomplished by the Discharge Monitoring Report Form (EPA No.3320-1), which must be submitted electronically no later than the 28th day of the month following the completed reporting period. See appendices for an example of this form. Copies of these electronic DMR reports must be submitted to the EPA via its database (Intergraded Compliance Information System, or ICIS)

Even if there is no discharge during the month, a report must be submitted stating, "No Discharge."

All records of operation, sampling, testing, and reporting must be kept on file for a minimum of three years and available for inspection. Sludge records must be kept for a minimum of five years. Many wastewater treatment systems do not discharge to surface waters and do not require a Montana Pollutant Discharge Elimination System (MPDES) permit. Some systems discharge to groundwater and require a Montana Ground Water Pollutant Control System (MGWPCS) permit; these would include infiltration percolation (I/P) cells, rapid infiltration basins, and drain fields. Groundwater permits limit pollutants, such as conductivity, chloride, nitrates, etc. Non-discharging systems do not discharge an effluent to surface or groundwater, and these include evaporation systems, and spray-irrigation or land application systems.

The Montana Department of Environmental Quality has the legal right of access to any facility to inspect the operations and records. The department has authority to initiate legal proceedings against any party in violation of the laws. The Montana Water Quality Act provides for a civil penalty of up to \$25,000 for violation of the rules, or effluent standards. Each day of violation

can be a separate violation. Willful or negligent violations can be a criminal offense with fines and imprisonment of up to one year.

**The personnel at DEQ want to work with communities and operators for improvement in water quality. Should any questions arise concerning operations, requirements, permits, or any other matter, the operator should feel free to call or write. If any change from normal operation is contemplated, it would be wise to contact DEQ Water Protection Bureau, Compliance and Technical Assistance staff for advice.**

## **II. BIOSOLIDS DISPOSAL**

Sewage sludge or “*biosolids*” are defined as the solid, semi-solid, or liquid residue generated during the treatment of domestic sewage in a wastewater treatment plant. Biosolids include scum or solids removed from domestic septage and solids removed from wastewater treatment lagoons. Biosolids do not include grit, screenings, or trash removed from the wastewater during preliminary treatment processes.

In 1993, the EPA implemented rules governing the disposal and recycling of biosolids. These rules are known as the Standards for the Use or Disposal of Sewage Sludge and are found under Chapter 40 of the Code of Federal Regulations, (40 CFR) *Part 503*. Most biosolids disposal and reuse practices are governed by these rules, including land application, surface disposal, and incineration. The State of Montana does not administer sludge disposal standards for EPA. Consequently, the local EPA office in Helena can be contacted at 406-457-5025 for more information regarding the proper disposal of biosolids.

### **LAND APPLICATION**

Land application is the most common form of biosolids disposal, and one of the most highly regulated by Part 503. In order to land apply biosolids, the material must not exceed established limitations for ten heavy metals, it must not exceed established limitations for pathogens, it must be adequately stabilized or isolated to reduce attraction to insects or other vectors, and the land application rate must match the nitrogen uptake rate of whatever vegetation exists at the application site. Records on how the sludge disposal practices satisfy the regulatory criteria must be maintained for at least five years.

### **SURFACE DISPOSAL**

Surface disposal practices are also governed by Part 503. Surface disposal differs from land application in that surface disposal is done without regard to nitrogen loading. In order to surface dispose of biosolids, the material must not exceed established limitations for three heavy metals, it must not exceed established limitations for pathogens, and it must be adequately stabilized or isolated to reduce attraction to vectors. Surface disposal ordinarily involves high-rate land application or burying sludge.

Another biosolids disposal alternative that is not covered by the Part 503 regulations is landfilling. **Landfilling** operations are governed by the **Part 257** regulations that require biosolids to be “non-hazardous” and “non-liquid.” Biosolids can be found “non-hazardous” by performing a test to show that the level of eight heavy metals in the material is below specific

limits. The material must also be tested for water content using the “Paint Filter Test.” If this test demonstrates that no water leaks out of the biosolids, then it can be declared “non-liquid.” If the biosolids material satisfies both requirements, it can be landfilled.

### **III. INDUSTRIAL PRETREATMENT**

Municipal wastewater treatment facilities are designed primarily for treating domestic wastewater. In most community sewer systems, there is a component of the wastewater that comes from commercial and/or industrial users that can contain substances that are not compatible with municipal wastewater treatment plants. The purpose of an Industrial Pretreatment Program is to give the municipality the ability to control or eliminate commercial/industrial discharges that can cause damage to the treatment works or interfere with treatment processes at the plant. An Industrial Pretreatment Program often includes the ability to control hauled waste and septage that is delivered directly to the collection system or treatment plant.

The EPA has implemented rules governing industrial discharges to municipal treatment facilities. These rules are known as General Pretreatment Regulations and are found under Chapter 40 of the Code of Federal Regulations, (40 CFR) **Part 403**. These regulations specify that all municipal wastewater treatment plants over 5 MGD (million gallons per day) and that receive waste from “Significant Industrial Users” that pass through or interfere with the treatment processes, must establish an Industrial Pretreatment Program sanctioned and approved by EPA. A Significant Industrial User is defined as a non-domestic and that discharges more than 25,000 gallons per day of industrial waste or is subject to specific categorical pretreatment standards under the Part 403 regulations.

With a comprehensive Industrial Pretreatment Program, the municipality has the ability to control or prohibit the discharge of dangerous or incompatible wastes to the collection and treatment system through the enforcement of Sewer Use Ordinances that set specific criteria for acceptable discharges. Typical Sewer Use Ordinance language includes limitations on waste characteristics such as explosivity, flammability, corrosivity, temperature, viscosity, solids content, etc. An Industrial Pretreatment Program also will include the ability to issue discharge “permits” to Significant Industrial Users to further control their contribution to the waste stream. These Industrial User permits may contain specific limitations on discharge quality, monitoring, and reporting requirements.

### **IV. OPERATOR CERTIFICATION**

Montana law (MCA 37-42-101) states that, “The health and welfare of Montana citizens are jeopardized by persons not properly qualified to operate the water supply systems and that Montana’s state waters are endangered by persons not properly qualified to operate the wastewater treatment plants.” The law continues “that the public policy of this state is to protect the public health and safety by certifying persons working in these occupations.”

All wastewater treatment plants and lagoon systems that meet the classifications outlined in ARM 17.40.202(1)(c) must be operated by at least one properly certified operator. The operator is certified by passing an examination and meeting certain experience and education

requirements for the class of facility operated. Lagoon operators for facilities using aeration are classified as Class 3C. Mechanical treatment plant operators will be Class 1C.

Unless granted a special exception, all operators are required to have a high school education (or G.E.D.). A 3C applicant must have one year of experience before becoming a fully certified operator.

### **THE KEY STEPS IN BECOMING A CERTIFIED OPERATOR ARE AS FOLLOWS:**

- Request Application (406/444-3434 or 406-444-4584)
- Read Information Received Thoroughly
- Fully Complete Application
- Determine the Class and Type of System
- Fill in All Applicable Experience (water and wastewater only)
- Fill in All Applicable Education
- Sign the Application and Mail Back with Fees
- Send Back Examination Notice by Deadline (15 days before exam)
- Receive Study Materials from Certification Office
- Take Examination and Wait for Results

Applicants who pass the examination but do not have the working experience can be issued a certificate as Operator in Training (OIT) until the experience requirement is met. Certification means that an applicant has the basic knowledge and skills necessary to operate any facility in that classification. Certification is not issued as a permit to operate only the plant in which the holder is currently employed. The applicant for a certificate should be knowledgeable in all types of systems within and below his or her certification grade.

**All fully certified operators must earn continuing education credits (CEC's).** These are earned by attendance at approved programs and classes. One credit is given for ten contact hours in the program or class. During a designated two-year period, all Class 2, 3, and 4 operators must earn one credit. This is the equivalent of ten hours of classroom or approved program participation. It is the operator's responsibility to see that all continuing education credits are submitted. Without these credits, renewal of certification will be denied.

Certified operators are required by law to be "readily available at all times." Problems often arise when least expected, which may require immediate action of the certified operator. The certified operator also acts as the contact person for DEQ staff who may find it necessary to call about some question or who may periodically inspect the wastewater system. To assure that at least one certified operator is always readily available, communities should have two certified operators or a back-up operator from a nearby community with a similar or greater level of certification.

Because certified operators are initially and continually trained, they offer the best protection for good operation and maintenance of treatment systems. In addition, by seeing that the treatment system is maintained to do its job in the best possible way, they also protect the large monetary investment made by the community, often with the support of the federal government. For further information on certification, you may call or write:

Water/Wastewater Operator Certification  
PO Box 200901  
Helena, MT 59620-0901  
Phone: 406-444-3434 or 406-444-4584

## CHAPTER 12

### I. MATH AND CALCULATIONS

*Problem solving is often a tough hurdle for people taking the certification examinations. The types of problems that the lagoon operator needs to know how to solve are included here. Most lagoons are either rectangular or variations of simple geometric shapes such as triangles.*

**The area of a rectangle is the Width times the Length.**

$$W \times L = \text{AREA}$$

$$120 \text{ ft} \times 500 \text{ ft} = 60,000 \text{ square feet. (ft}^2\text{)}$$

**Now, if we multiply the area by the depth, we get Volume.**

$$W \times L \times D = \text{VOLUME}$$

$$120 \text{ ft} \times 500 \text{ ft} \times 5 \text{ ft} = 300,000 \text{ cubic feet (ft}^3\text{)}$$

Note that all dimensions are in the same unit of feet. You cannot multiply, divide, add or subtract using different units.

To convert the cubic feet of volume of the lagoon cell into gallons, we must multiply by the number of gallons in each cubic foot which is 7.48.

1 cubic foot of water = 7.48 gallons

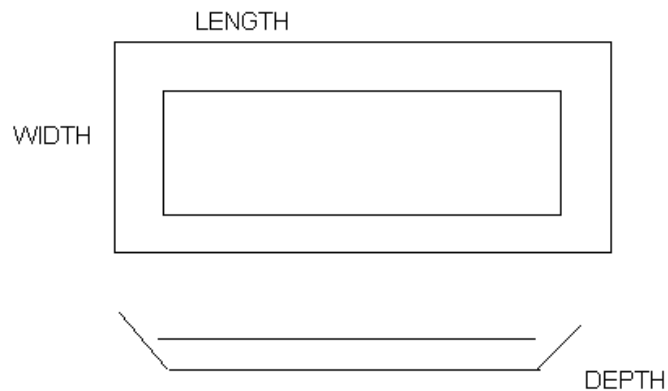

$$\text{VOLUME IN GAL} = \text{LENGTH} \times \text{WIDTH} \times \text{DEPTH} \times 7.5 \text{ GAL/CF}$$

$$120 \text{ ft} \times 500 \text{ ft} \times 5 \text{ ft} \times 7.48 \text{ gal/cf} = 2,250,000 \text{ gal.}$$

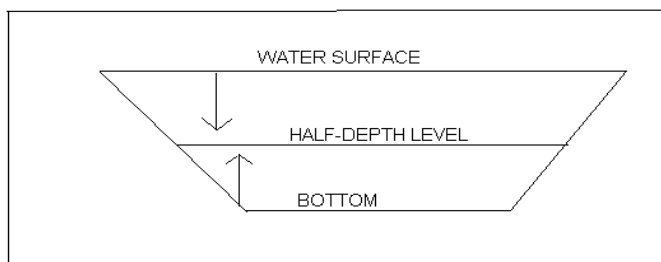

The calculation of volume using  $W \times L \times D$  where  $W$  and  $L$  are the width and length of the surface of the lagoon would be correct if the sides of the lagoon cell were vertical. Many calculations can be simplified by making that assumption. But for more accurate calculations, we must remember that the sides are sloping, and the use of surface measurements will result in a high value for the volume. In determining the volume of a smaller lagoon cell such as

those used in aerated lagoons, you must consider the slopes of the sides of the dikes to make an accurate determination of volume.

To get a true value, the half-depth measurements should be used. Most lagoon banks are constructed with a slope of 3 feet horizontal to 1 foot vertical. If the water depth is 5 feet, the dimensions at the half-depth level, (the 2.5-foot level), will be 3 x 2.5 ft, or 7.5 feet shorter than the surface at each end and at each side of a rectangular cell. For a 5-foot-deep lagoon, each dimension will be reduced by twice the 7.5 feet shortening of each bank, for a total of 15 feet. This correction to surface measurements is:

$$\begin{aligned} \text{Width} &= \text{surface dimension} - (\text{slope} \times \text{depth}) \\ \text{Length} &= \text{surface dimension} - (\text{slope} \times \text{depth}) \end{aligned}$$

If we apply these corrections to the problem above where surface dimensions are  $W = 120 \text{ ft}$ ,  $L = 500 \text{ ft}$ ,  $D = 5 \text{ ft}$

$$\begin{aligned} W &= 120 \text{ ft} - (3 \times 5 \text{ ft}) \\ &= 120 \text{ ft} - 15 \text{ ft} \\ &= 105 \text{ ft} \end{aligned}$$

$$\begin{aligned} L &= 500 \text{ ft} - (3 \times 5 \text{ ft}) \\ &= 500 \text{ ft} - 15 \text{ ft} \\ &= 485 \text{ ft} \end{aligned}$$

The corrected volume would then be

$$\begin{aligned} \text{Volume} &= 105 \text{ ft} \times 485 \text{ ft} \times 5 \text{ ft} \\ &= 254,625 \text{ cubic ft} \end{aligned}$$

Multiply cubic feet by 7.5 to convert to gallons

$$\begin{aligned} \text{Volume} &= 254,625 \text{ CF} \times 7.5 \text{ gal/cf} \\ &= 1,909,687.5 \text{ gallons} \end{aligned}$$



## DETENTION TIME

One problem that uses the volume calculations described above is the *detention time*. Detention is the total volume divided by the flow rate:

$$\frac{V}{Q} = \text{Detention Time}$$

$V = \text{volume}$   
 $Q = \text{flow rate}$   
 $Dt = \text{Detention time}$

In the example on the previous page, the total calculated volume is 1,909,687 gallons. If the flow rate is 100,000 gallons per day, then the detention time is calculated as:

$$\frac{1,909,687 \text{ GAL}}{100,000 \text{ GAL/DAY}} = 19.1 \text{ DAYS}$$

The detention time calculated in this way is a theoretical number. It does not mean that every gallon of water is held in the cell for that length of time. As there is mixing in cells, from aerator mixing in aerated lagoons, or from wind or other sources in non-aerated lagoons, some of the incoming water may reach the outlet much earlier, and some much later than the time calculated as detention time. The calculated detention time could be considered an average time that water remains in the lagoon cell.

The detention time calculated in this way is valuable in design and for estimating hydraulic loading. Montana facultative lagoon systems should have at least 180 days of detention time excluding volume set aside for sludge storage.

## RATE OF DISCHARGE

Usually the worst quality effluent from facultative lagoons occurs right after the lagoon ice melts. This is followed by a "turnover" as described in the Chapter 4. The poor-quality effluent condition may last for several weeks. Also, some lagoons experience a poor quality in late summer when high algae blooms may occur. This condition may last for a month or more depending on weather and loading conditions.

A method of controlling the quality of the effluent and to prevent violation of permit limits is to hold the wastewater and to not discharge during periods of poor treatment. This requires that the operator draw down the lagoon level during periods of good treatment prior to these poor treatment periods, so that water can be held, and no discharge need be made during poor treatment periods. An important consideration is that the draw down must be in compliance and within the limitations of the discharge permit.

Past records should show an approximate date and length of time that quality will be low, and discharge should be discontinued. From that can be calculated how far to draw down, the rate of discharge to draw and when to start the *draw-down*.

Using the  $W \times L \times D = \text{Volume}$  equation, calculate the volume for each foot of level.

$W \times L \times 1 \text{ ft} = \text{cubic feet per foot.}$   
 $\text{Cubic feet} \times 7.5 \text{ gallons per cubic foot} = \text{gal per foot}$

If you know the number of acres in your lagoon system, multiply the acres  $\times$  43,560 sq ft/acre  $\times$  7.5 gal/cf to get gallons per foot of level.

For example:

If a lagoon system had three 5-acre cells, volume per foot of depth would be:

$$3 \times 5\text{-acre} \times 43,560 \text{ sq ft/acre} \times 1 \text{ ft} = 653,400 \text{ cubic ft.}$$

$$653,400 \text{ cubic ft} \times 7.5 \text{ gallons/CF} = 4,900,500 \text{ gal/ft}$$

If the normal discharge rate is 100,000 gal/day, then the holding time per foot of level is:

$$\frac{4,900,500 \text{ gal}}{100,000 \text{ gal/day}} = 49 \text{ days of holding time per foot}$$

To lower the level by one-foot means that 4,900,500 gallons in flow, over the normal discharge volume, will have to be made to lower the level by one foot. If a 60-day period is used for the draw-down, the rate of discharge would be:

$$\frac{4,900,500 \text{ gallons}}{60 \text{ days}} = 81,675 \text{ gallons per day.}$$

To this must be added the normal daily discharge of 100,000 gallons, so the total discharge is the sum of the two.

$$81,675 \text{ gal} + 100,000 \text{ gals} = 181,675 \text{ gal/day.}$$

Most facultative lagoons have up to 3 feet of draw-down available. They should not be drawn below the 2-foot level as the quality of water in the lower 2 feet is usually of poor quality and would likely not meet permit requirements.

If the lagoon operator knew from experience that discharge should be discontinued on March 1 and water held for six weeks, then draw-down would need to begin about January 1 in the example case.

All calculations, and data such as the actual draw-down rate, and the refill rate should be recorded for use in following years.

## **BOD and TSS REMOVAL**

One of the main reasons to treat wastewater in a lagoon is to reduce the amount of organic waste before allowing the water to flow into a stream. The organic waste is measured by the Biochemical Oxygen Demand (BOD) test which is described in another part of this manual. Most discharge permits require an 85 *percent removal* in BOD and Total Suspended Solids (TSS).

A standard formula for calculating pounds of anything if we know the concentration (mg/l) and flow rate is:

$$\text{lbs/day} = \text{mg/L} \times \text{million gal/day} \times 8.34 \text{ lb/gal}$$

The number 8.34 is the weight in pounds of 1 gallon of water.

To use this formula, first change the flow rate into millions of gallons per day. If the flow rate is in gallons per day, just divide by 1,000,000. 500,000 gallons per day would be 0.5 mgd, or 50,000 would be 0.05 mgd. If the flow rate is measured in gallons per minute, multiply by 1,440 minutes per day and divide by 1,000,000. (60 min/hr x 24 hrs/day = 1,440 min/day). Use the actual test number for mg/l.

For example, if we have a raw sewage test of 220 mg/l BOD and the flow is 100,000 gallons per day, then the pounds of BOD entering the treatment system is:

$$\begin{aligned} \text{lbs/day} &= 220 \text{ mg/L} \times 0.1 \text{ mgd} \times 8.34 \\ \text{lbs/day} &= 183.5 \text{ lbs/day of BOD} \end{aligned}$$

Now, we can do the same calculation on the effluent. If we assume that the test on the discharge water (effluent) is 30 mg/l BOD going out of the system, and the flow is the same:

$$\begin{aligned} \text{lbs of BOD} &= 30 \text{ mg/L} \times 0.1 \text{ mgd} \times 8.34 \text{ lb/gal} \\ \text{lbs of BOD} &= 25 \text{ lbs/day of BOD.} \end{aligned}$$

$$\text{The pounds of removal} = 183.5 \text{ lbs} - 25 \text{ lbs or } 158.5 \text{ lbs}$$

$$\text{The percent removal is} = \frac{\text{load in} - \text{load out}}{\text{total load}} \times 100$$

$$\frac{158.5 \text{ lbs} \times 100}{183.5 \text{ lbs}} \quad \% \text{ removal} = 86.4\%$$

The same calculation can be used for total suspended solids (TSS) to determine the pounds coming in, the pounds going out, and percent removal.

## **BOD PER CAPITA**

A standard number is used for design purposes which estimates the average amount of BOD contributed by each person in a community, generally accepted as 0.20 pounds BOD per day per person. It is called the population equivalent. So, theoretically, a town of 1,000 population would have a sewage load of 200 pounds of BOD to treat. This number, in practice, may vary, but for domestic sewage without a high BOD source like a milk processing plant, it is quite good. If you have the daily sewage flow and the average BOD for the raw sewage, you can calculate your own community population equivalent. Remember the standard formula for finding pounds.

$$\text{Pounds per day} = \text{mg/L} \times \text{mgd} \times 8.34 \text{ lb/gal}$$

That will give you the pounds of BOD per day. Divide by your community population and you will have it.

Example: 350,000 gal per day at 180 mg/l BOD  
lbs BOD = 180 mg/L x .350 mgd x 8.34 lb/gal  
lbs BOD = 525.4 lbs.

If the population is 2,900 people

Population Equivalent =  $\frac{525.4}{2,900} = 0.18$  lbs BOD/person

## DOSAGE

The same formula for pounds of BOD can be used for any chemical *dosage*. If you need to calculate the amount of chlorine to add, this is the same formula. Use the dose of chlorine in mg/l. If you wish to add 3 mg/l of chlorine to your effluent, the lbs = mg/l x mgd x 8.34 will give the answer. In 150,000 gallons per day, it would be:

$$\begin{aligned}\text{Pounds chlorine} &= 3.0 \text{ mg/L} \times 0.15 \text{ mgd} \times 8.34 \text{ lb/gal} \\ &= 2.5 \text{ pounds chlorine per day.}\end{aligned}$$

Another form of this standard formula will give you the dosage *if you know the pounds*:

$$\text{mg/L} = \frac{\text{pounds}}{\text{mgd} \times 8.34 \text{ lb/gal}}$$

So, if your chlorinator reads 8.7 lb/day being added to the 350,000 gal/day flow, your dosage would be:

$$\text{mg/L} = \frac{8.7 \text{ lb/day}}{.350 \text{ mgd} \times 8.34 \text{ lb/gal}}$$

$$\text{mg/L} = 2.98 \text{ mg/L}$$

## BOD LOADING

An important parameter in lagoon design and operation is the *BOD loading*. In the northern states, like Montana, a loading of 20 pounds of BOD per acre of lagoon area is mostly used. When BOD loading is too high, the lagoons can fail due to overload. For calculation of the loading, the total surface area must be known. This area must be converted to acres by dividing by 43,560 (number of square feet in an acre).

The BOD load can be calculated as above, using the standard formula, or it might be found by using the population equivalent. If we take the numbers we used above, and assume that our lagoon is 800 ft x 1500 ft, we have:

$$800 \text{ ft} \times 1500 \text{ ft} = 27.5 \text{ acres} \quad (@43560 \text{ sq ft/ acre})$$

$$\frac{525.4 \text{ lbs BOD}}{27.5 \text{ acres}} = 19.1 \text{ lbs BOD/Acre/day loading.}$$

## HYDRAULICS

The basic formula for hydraulic flow is:

$$Q = A \times V$$

Q = the Quantity of water in cubic feet per second

A = the Area of the pipe or channel

V = the Velocity of the flowing stream in feet per second

$Q = A \times V$  simply states that the size of the pipe or channel and the rate at which water is running determine the quantity that is delivered. All of which is common sense. The equation puts it into mathematical form.

Using this formula requires calculation of area and conversion of cubic feet per second to units more commonly used, usually gallons per minute or million gallons per day.

The cross-section area of a pipe is a circle. The formula for area of a circle is:

$$A = 3.1416 \times R^2$$

or it may be written  $A = 3.1416 \times \frac{D^2}{4}$

or  $A = 0.785 \times D^2$

In finding the cross section of pipe, be sure you convert the pipe diameter from inches to feet. For instance, a 6" pipe has a diameter of 0.5 ft. 8" is 0.667 ft diameter.

For example, if water is flowing through a 6" pipe at a velocity of 4 feet per second, the quantity of water flowing is:

$$\text{Area of 6" pipe} = \frac{0.5 \text{ ft} \times 0.5 \text{ ft} \times 3.14}{4} = 0.196 \text{ sq ft}$$

$$\begin{aligned} \text{Quantity} &= 0.196 \text{ sq ft} \times 4 \text{ ft/sec} \\ &= 0.785 \text{ cubic feet per second.} \end{aligned}$$

As there are 7.48 gallons in each cubic ft, and there are 60 seconds in each minute, this flow rate can be converted to gallons per minute by multiplying:

$$\begin{aligned} \text{GPM} &= 0.785 \text{ CFS} \times 7.48 \text{ gal/CF} \times 60 \text{ sec/min} \\ &= 352 \text{ gallons per minute} \end{aligned}$$

Flow in a rectangular shaped channel can be calculated by using  $\text{Width} \times \text{Depth} = \text{Area}$

**The formula sheet developed by DEQ for assisting operators in solving math problems is attached at the end of this chapter, following the self-study questions. These formulas should be used and understood by the operator in preparation for the Certification Exam.**

# FORMULA SHEET

## Abbreviations:

in	inches	ppm	parts per million
ft	feet	mg/L	milligrams per liter
in <sup>2</sup>	square inches (sq. in.)	hp	horsepower
ft <sup>2</sup>	square feet (sq. ft.)	psi	pounds per square inch
ft <sup>3</sup>	cubic feet (cu. ft.)	kWh	kilowatt hours
hr	hours	kW	kilowatts
min	minutes	kPa	kilopascal
sec	seconds	Nt	Newton
d	diameter <i>or</i> day (usually days)	V	velocity <i>or</i> volume
<b>PERMIT LIMIT (30)</b>			
gal	gallons	m	meter
MG	million gallons	cm	centimeter
Q	flowrate	mm	millimeter
gpd	gallons per day (gal/d)	km	kilometer
gph	gallons per hour (gal/h)	mL	milliliter
gpm	gallons per minute (gal/min)	g	gram
MGD	million gallons per day	mg	milligram
cfs	cubic feet per second (ft <sup>3</sup> /sec)	kg	kilogram

## Conversion Factors:

### Length:

12 in = 1 ft  
5280 ft = 1 mile

### Area:

1 ft<sup>2</sup> = 144 in<sup>2</sup>  
1 acre = 43,560 ft<sup>2</sup>

### Volume:

1 ft<sup>3</sup> = 7.48 gal  
1 acre-foot = 0.326 MG

### Time:

1 min = 60 sec  
1 hr = 60 min = 3600 sec  
1 d = 24 hr = 1440 min  
1440 min = 86,400 sec

### Temperature:

$T(^{\circ}\text{F}) = T(^{\circ}\text{C}) \times 1.8 + 32.2$   
 $T(^{\circ}\text{C}) = [T(^{\circ}\text{F}) - 32.2] / 1.8$

### Flowrate:

1 cfs (ft<sup>3</sup>/sec) = 448.8 gpm  
1 MGD = 1.55 cfs = 694.4 gpm  
1 gpm = 60 gal/hr = 1440 gal/d  
1 gal/hr = 24 gal/d

### Power & Energy:

1 kW = 1.341 hp  
1 kW-hr = 2.655 x 10<sup>6</sup> ft lbs  
1 hp = 33,000 ft-lb/min  
= 550 ft-lb/sec

### Force & Pressure:

1 Nt = 0.115 lb (force)  
1 kPa = 0.146 psi (pressure)  
1 psi = 2.31 ft (pressure head)  
0.433 psi = 1 ft (pressure head)

## Metric Conversion Factors:

### Length:

1000 mm = 1 m  
 100 cm = 1 m  
 1000 m = 1 km  
 2.54 cm = 1.0 in  
 1.0 km = 0.62 mi

### Volume:

1000 mL = 1.0 L  
 1.0 m<sup>3</sup> = 1000 L  
 3785 mL = 1 gallons  
 2.63 mL/min = 1 gal/d

### Weight or Mass:

1.0 kg = 1000 g  
 1.0 g = 1000 mg  
 1 kg = 2.20 lb  
 1 lb = 16 oz

### Concentration:

1 mg/L = 1 ppm

## Example Conversions:

$$\text{Area (in}^2\text{)} = \text{Area (ft}^2\text{)} \times 144 \text{ (in}^2\text{/ft}^2\text{)}$$

$$Q \text{ (ft}^3\text{/sec)} = Q \text{ (MGD)} \times 1.55 \text{ (cfs/MGD)}$$

$$\frac{\text{time (days)}}{\text{time (min)}} = \frac{1440 \text{ min/day}}{1440 \text{ min/day}}$$

$$V \text{ (ft/sec)} = \frac{Q \text{ (gpm)}}{A \text{ (ft}^2\text{)} \times 448.8 \text{ (gpm/cfs)}}$$

$$\text{Energy (kW-hr)} = \frac{\text{Power (hp)} \times \text{time (hr)}}{1.341 \text{ (hp/kW)}}$$

$$\text{Detention time (hr)} = \frac{V \text{ (ft}^3\text{)}}{Q \text{ (cfs)} \times 3600 \text{ (sec/hr)}}$$

**Geometry:** where  $V$  is volume,  $Q$  is flowrate, and  $A$  is area.

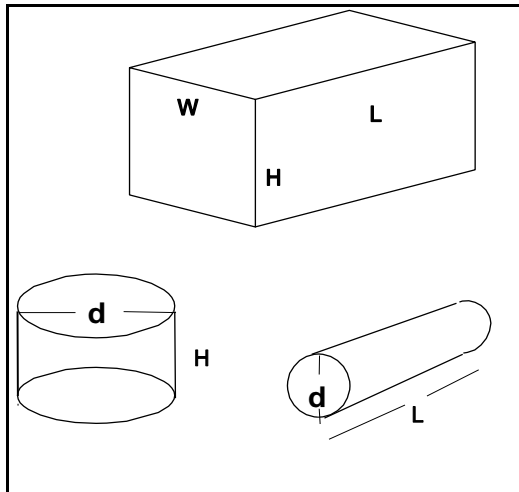

### Rectangular tank:

$$\text{Area} = \text{length} \times \text{width (top)}$$

$$= \text{height} \times \text{width (vertical cross-section)}$$

$$\text{Volume} = \text{length} \times \text{width} \times \text{height}$$

### Circular tank: (note: $(\pi/4)$ is = to 0.785)

$$\text{Circumference} = \pi \times d \text{ or } 3.14 \times d$$

$$\text{Area} = (\pi/4) \times d^2$$

$$\text{Volume} = (\pi/4) \times d^2 \times H \text{ (tank)}$$

$$= (\pi/4) \times d^2 \times L \text{ (pipe)}$$

NOTE: If all dimensions are in feet, area will be in ft<sup>2</sup> and volume in ft<sup>3</sup>. For pipes, convert pipe diameter to dimensions of *feet* before using the above formula.



## Basic Hydraulics:

### Detention and Delivery Times:

$$\text{Detention Time (min)} = \frac{\text{Tank capacity (gal)}}{\text{flowrate (gpm)}}$$

$$\text{Detention Time (days)} = \frac{\text{Tank capacity (MG)}}{\text{flowrate (MGD)}}$$

### Flowrate, Area and Volume:

$$\text{Velocity (ft/sec)} = \frac{\text{Flowrate (cfs)}}{\text{Area (ft}^2\text{)}}$$

$$\text{Area} = \frac{\text{Flowrate}}{\text{Velocity}}$$

$$\text{Delivery Time (hr)} = \frac{\text{Pipe Length (ft)}}{\text{Flow Velocity (ft/sec)} \times 3600 \text{ (sec/hr)}} = \frac{\text{Pipe Volume (ft}^3\text{)}}{\text{Flowrate (gpm)} \times 8.02 \text{ (ft}^3\text{/hr/gpm)}}$$

$$\text{Flowrate (ft}^3\text{/sec)} = \text{Velocity (ft/sec)} \times \text{Area (ft}^2\text{)}$$

or  $Q = V \times A$ , where Q is flowrate, V is velocity and A is cross-sectional area.

### Specific capacity (of a well):

$$\text{Specific capacity} \left( \frac{\text{gpm}}{\text{ft}} \right) = \frac{\text{Pumping rate (gal/min)}}{\text{Drawdown in well (ft)}}$$

**Volume Pumped (gal):** pumping rate (gpm) x time (min)

### Force, Pressure, and Water:

Water weighs 8.34 lb/gal or 62.4 lb/ft<sup>3</sup>.

A column of water 2.31 feet high exerts a pressure of 1.0 psi at its base.

A column of water 1.0 feet high exerts a pressure of 0.433 psi or 62.4 lb/ft<sup>2</sup> at its base.

$$\begin{aligned} \text{Force (lb)} &= \text{Pressure (psi)} \times \text{Area (in}^2\text{)} \\ &= \text{Pressure (psi)} \times \text{Area (ft}^2\text{)} \times 144 \text{ (in}^2\text{/ft}^2\text{)} \end{aligned}$$

$$\text{Line Losses (ft of water)} = \text{Head Loss Rate (ft of water per ft)} \times \text{Pipe Length (ft)}$$

**Concentration and Dose** (NOTE: ppm = mg/L) Volume: Capacity or Flowrate

## Dosage or Dose

dosage (lb)/day = concentration (mg/L) x volume (MG) x 8.34 lbs/gal

lbs/day = mg/L x MG x 8.34 or

lbs/day = mg/L x gpm x 0.012

$$\text{mg/L} = \frac{\text{lbs}}{\text{MG} \times 8.34}$$

$$\text{MG} = \frac{\text{lbs}}{\text{mg/L} \times 8.34}$$

## Concentration (mg/l):

C is the final delivered concentration, Q is the total flowrate treated, C<sub>f</sub> is the concentration in the feed solution, and Q<sub>f</sub> is the rate of feed solution addition. This formula assumes zero concentration in the water prior to adding the feed solution.

$$C \text{ (mg/L)} = \frac{C_f \text{ (mg/L)} \times Q_f \text{ (mL/min)}}{Q \text{ (gpm)} \times 3785 \text{ mL/gal}}$$

## Efficiency and Percentage:

**Removal efficiency:**

$$\% \text{ removal} = \frac{(C_{in} - C_{out})}{C_{in}} \times 100\%$$

**Chemical delivery:**

$$\text{Chemical delivery (\%)} = \frac{\text{lbs active compound delivered}}{\text{lbs raw chemical used}} \times 100\%$$

## Discharge to a Stream:

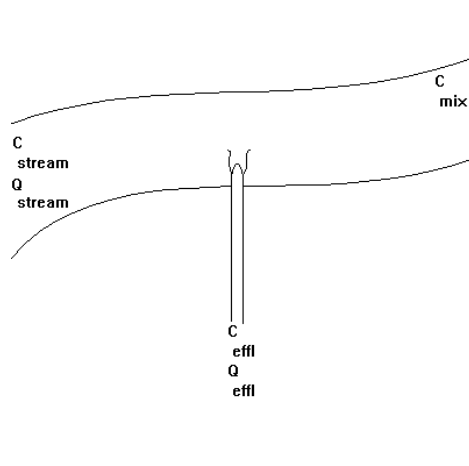

Where C is concentration and Q is flowrate. Note that all flowrates must be in the same units, and all concentrations must be in the same units (e.g., cfu/ml, mg/L, lb/gal). This formula assumes complete mixing of the effluent with the stream.

$$C_{mix} = \frac{(C_{stream} \times Q_{stream}) + (C_{effl} \times Q_{effl})}{Q_{stream} + Q_{effl}}$$

**Hydraulics and Loading Rates:**

**Surface Settling Rate (SSR),  
Upflow Rate, or Hydraulic Loading  
Rate (HLR):**

$$\text{HLR} \left( \frac{\text{gal/d}}{\text{ft}^2} \right) = \frac{\text{Totalflow (gpd)}}{\text{WaterSurface Area (ft}^2\text{)}}$$

$$\text{HLR} \left( \frac{\text{ft}^3}{\text{ft}^2 \times \text{min}} \text{ or } \frac{\text{ft}}{\text{min}} \right) = \frac{\text{Total flow (ft}^3\text{/min)}}{\text{WaterSurface Area (ft}^2\text{)}}$$

### Weir Loading Rate (WLR):

$$\text{Weir Loading Rate} \left( \frac{\text{gal/d}}{\text{ft}} \right) = \frac{\text{TotalFlow (gal/d)}}{\text{length of weir(ft)}}$$

### Organic Loading Rate (OLR) or Surface Loading Rate (SLR):

$$\text{OLR (lb BOD per day per ft}^2\text{)} = \frac{\text{BOD (mg/L)} \times \text{Flowrate (MGD)} \times 8.34 \text{ lb/gal}}{\text{Area(ft}^2\text{)}}$$

### Pump horsepower requirements:

P is pump horsepower, Q is flowrate, H is pump head (pressure) and E is pump/motor efficiency. Note that efficiency is used as a fraction, not a percentage, in these formulas. Use the formula that matches your units.

$$P \text{ (hp)} = \frac{Q(\text{gpm}) \times H(\text{ft})}{3960 \times E} \text{ or } \frac{Q(\text{gpm}) \times H(\text{psi})}{1714 \times E} \text{ or } \frac{Q(\text{cfs}) \times H(\text{psi})}{3.82 \times E} \text{ or } \frac{Q(\text{MGD}) \times H(\text{ft})}{5.7 \times E}$$

### Specific Gravity (S.G.)

$$\text{S.G.} = \frac{\text{Density of Solution (lb/ft}^3\text{)}}{\text{Density of Water (lb/ft}^3\text{)}}$$

# **APPENDICES**

---

**Study Materials for Wastewater Exams**

**Wastewater Terms**

**Example of Discharge Monitoring Report**

**Log Sheets**

**Trend Charts**

## Study Material for Wastewater Exams

Montana DEQ would suggest studying the new WEF Study manual “Wastewater Treatment

Fundamentals Volume I” prepared by the Water Environment Federation (WEF) and Association of Boards of Certification (ABC). Operators that have used this reference have consistently scored higher on the examinations than those who do not use the above referenced manual. There is a second manual on Solids Handling available.

<https://www.wef.org/resources/publications/books/wastewater-treatment-fundamentals/>  
Wastewater Treatment Fundamentals Volume

<https://www.youtube.com/watch?v=b4D6Oalo2eg>  
Wastewater training video 1 of 3

<https://www.youtube.com/watch?v=JcoNDThNwYk&t=2578s>  
Wastewater training video 2 of 3

<https://www.youtube.com/watch?v=TcvjQ5Pv-8A>  
Wastewater training video 3 of 3

<https://www.youtube.com/watch?v=qRNG-RwxIKc&t=43s>  
Wastewater math video. This is the first in the series, but the trainer has many other videos.

<https://royceu.com/public/PracticeQuizes.aspx>  
Practice Exam

[http://www.sewergeek.com/sewer\\_geek/Practice\\_Exams.html](http://www.sewergeek.com/sewer_geek/Practice_Exams.html)  
Practice Questions

<https://www.cram.com/flashcards/wef-wastewater-operators-practice-exam-1959477>  
Some useful flashcards.

Other references include “Operation of Wastewater Treatment Plants,” first three volumes, prepared by California State University, Sacramento written by Kenneth D. Kerri. <http://www.owp.csus.edu/courses/wastewater/operation-of-wastewater-treatment-plants-vol-i.php>

“Pumps and Pumping” by Skeet Arasmith, <https://store.awwa.org/store/productdetail.aspx?productid=28452> “Pumping,” by Frank R. Spellman and Joanne Drinan, <https://www.amazon.com/Pumping-Fundamentals-Wastewater-Maintenance-Operator/dp/1587160145> and MOP11 “Operation of Municipal Wastewater Treatment Plants,” from the Water Environment Federation, all three volumes.

Study guides from the American Water Works Association, “Wastewater Operator Certification Study Guide”

<https://www.awwa.org/store/productdetail.aspx?productid=6666> and “Operation of Municipal Wastewater Treatment Plants Study Guide,” from the Water Environment Federation would also help.

Operators that have used the study guides seem to do better in the classes but that might just be my impression.

Also, some of the books are available as E-Books

Amazon list of Study Guides for Wastewater Certification Exams

[https://www.bing.com/search?q=wef%2fab%2fc2ep+wastewater+operators%27+guide+to+preparing+for+the+certification+examination+water+environment+federation&filters=ufn%3a%22wef%2fab%2fc2ep+wastewater+operators+guide+to+preparing+for+the+certification+examination+water+environment+federation%22+sid%3a%220f6775a8-83a4-b93b-e2cf-a48dec75cf5a%22+catguid%3a%22c91495d2-db0a-7810-fa95-e34f4d6c71ed\\_cfb02057%22+segment%3a%22generic.carousel%22&FORM=SNAPST](https://www.bing.com/search?q=wef%2fab%2fc2ep+wastewater+operators%27+guide+to+preparing+for+the+certification+examination+water+environment+federation&filters=ufn%3a%22wef%2fab%2fc2ep+wastewater+operators+guide+to+preparing+for+the+certification+examination+water+environment+federation%22+sid%3a%220f6775a8-83a4-b93b-e2cf-a48dec75cf5a%22+catguid%3a%22c91495d2-db0a-7810-fa95-e34f4d6c71ed_cfb02057%22+segment%3a%22generic.carousel%22&FORM=SNAPST)

List of online resources. (These can change over time and may not be up to date.)

[http://www.abccert.org/testing\\_services/study\\_guides.asp](http://www.abccert.org/testing_services/study_guides.asp)

<http://www.cram.com/flashcards/wastewater-operator-certification-study-guide-level-i-1961692>

<http://www.cram.com/flashcards/wef-wastewater-operators-practice-exam-1959477>

<http://www.cram.com/flashcards/wastewater-exam-01-328486>

<http://www.cram.com/flashcards/wef-wastewater-treatment-level-i-ii-operator-study-questions-1958547>

<http://www.cram.com/flashcards/wastewater-practice-questions-967388>

<https://quizlet.com/24487145/wastewaterpractice-exam-flash-cards/>

<https://quizlet.com/21269602/wastewater-operator-certification-study-guide-grade-1-flash-cards/>

<https://quizlet.com/208936274/operation-of-wastewater-treatment-plants-volume-i-7th-edition-flash-cards/>

[http://www.abccert.org/testing\\_services/sample\\_exam\\_questions.asp](http://www.abccert.org/testing_services/sample_exam_questions.asp)

<http://www.dem.ri.gov/programs/benviron/water/licenses/wwoper/pdfs/gr1study.pdf>

<https://www.waterandwastewatercourses.com/practice-problems-wastewater-operator/>

<https://americanwatercollege.org/course/wastewater-treatment-exam-review-grade-1/>

<http://onesourcebook.com/download/wastewater-test-questions-and-answers.pdf>

[https://www.tpomag.com/online\\_exclusives/2014/02/exam\\_study\\_guide\\_activated\\_sludge\\_troubleshooting](https://www.tpomag.com/online_exclusives/2014/02/exam_study_guide_activated_sludge_troubleshooting)

From the state of Kentucky operator certification

<http://dca.ky.gov/certification/Test%20Preparation%20Documents/WWCollectionManual-Rev04.20.2015.pdf>

From the state of Wisconsin operator certification

<https://dnr.wi.gov/regulations/opcert/documents/WWSGGeneralINTRO.pdf>

<https://dnr.wi.gov/regulations/opcert/documents/StudyGuideBasicGeneral.pdf>

from the state of New Mexico operator certification

<https://www.env.nm.gov/swqb/FOT/WastewaterStudyManual/WastewaterOperatorStudyManual.pdf>

Sample questions from the state of Illinois

<http://www.epa.state.il.us/water/operator-cert/waste-water/study-guide/operator-in-training.pdf>

Collection system questions

[http://www.sewergeek.com/sewer\\_geek/Practice\\_Exams.html](http://www.sewergeek.com/sewer_geek/Practice_Exams.html)

<https://www.youtube.com/watch?v=82zIGD2THns>

Free Tests

<http://royceu.com/Public/PracticeQuizes.aspx>

<https://www.jobtestprep.com/civil-water-wastewater-treatment-exam-practice>

<https://americanwatercollege.org/exam-prep/>

<https://www.octwqa.org/index.php/practice-exams>

<http://www.wvrwa.org/shared/content/ClassIIIWastewaterClassIIIReviewQuestions-August2004.pdf>

Online courses

<https://www.waterandwastewatercourses.com/>

<http://www.train2retain.net/> (cost per module)

Indigo Water Group has classes and practice exams and also has a study session

<https://www.indigowatergroup.com/training-gateway/>

This practice exam costs to take

<https://www.approvedce.com/PracticeExam/examRegistration.asp>

## **WASTEWATER TERMS**

**Acid:** A substance that tends to lose a proton, dissolves in water with the formation of hydrogen ions, contains hydrogen, which may be replaced by metals to form salts. Highly corrosive.

**Acre Foot:** A volume of water one (1) foot deep and one (1) acre in area, or 43,560 cubic feet.

**Activated Sludge:** Sludge grown in aeration tanks in the presence of dissolved oxygen, which teems with bacteria, fungi and protozoa.

**Activated Sludge Process:** Biological wastewater treatment process that speeds up the decomposition (stabilization) of wastes in wastewater. Activated sludge is added to wastewater and the mixture (mixed liquor) is aerated and agitated followed by sedimentation (settling). Some settled sludge is returned (return sludge) to the aeration tank to maintain activated sludge population.

**Advanced Waste Treatment:** Any process that upgrades the level of wastewater treatment beyond conventional treatment processes to meet specific reuse requirements, such as chemical treatment and pressure filtration. (Also called Tertiary Treatment.)

**Aeration:** The process of adding air to wastewater to provide dissolved oxygen for aerobic bacterial treatment, to freshen wastewater and to keep solids in suspension.

**Aeration Tank:** Basin used to mix raw wastewater with return activated sludge and aerate the mixed liquor.

**Aerobic:** The condition in which free oxygen is dissolved in the water. Aerobic Bacteria need free oxygen to live and multiply.

**Aerobic Digestion:** Breakdown of wastes in the presence of dissolved oxygen. Process used to further stabilize solids removed from WWTPs in aerobic digesters.

**Algae:** A class of microscopic plant life that contain chlorophyll, live floating (suspended) in water or are attached to rocks, walls and other surfaces, and grow and multiply through photosynthesis. Algae produce oxygen during sunlight hours, use oxygen during darkness and affect the pH and DO levels in water.

**Algal Bloom:** Sudden, massive growths of algae that develop in lagoons, lakes and reservoirs.

**Alkalinity:** The capacity of water to neutralize acids; the buffering capacity of water to resist changes in pH, especially with regard to acids, the effects of chlorine addition and the Denitrification process.

**Anaerobic:** The condition in which there is no, or very little, free dissolved oxygen in the water. Anaerobic bacteria live in the absence of free oxygen, but they are able to obtain their oxygen from combined oxygen that exists in chemical compounds. Some treatment lagoons are purposely operated in an anaerobic state. Odors are often associated with anaerobic (septic) conditions due to formation of hazardous hydrogen sulfide gas.

**Anaerobic Digestion:** Anaerobic bacteria (saprophytic and methane fermenters) decompose wastewater solids (complex organic material) in two steps into: 1) volatile acids, and 2) methane gas, carbon dioxide and water in the absence of dissolved oxygen. Specially designed basins, digesters, are used to carry out the digestion processes, prevent air from entering and to capture the methane gas. The sludge layer at the bottom of lagoons provides for similar solids stabilization processes.

**Aquifer:** A natural underground layer of porous materials usually capable of yielding a supply of water.

**Available Chlorine:** The amount of chlorine available in compound chlorine sources compared with that of elemental (liquid or gaseous) chlorine.



---

**Bod:** (Pronounce letters separately.) The Biochemical Oxygen Demand test measures the rate at which microorganisms use oxygen while decomposing organic matter under aerobic conditions. BOD is used as a measure the organic strength of wastewater.

**Backflow:** A reverse flow condition, created by a difference in water pressures, which causes water to flow back into the distribution pipes of a potable water supply from any source or sources other than an intended source. Also see BACKSIPHONAGE.

**Backsiphonage:** A form of backflow caused by a negative or below atmospheric pressure within a water system. Also see BACKFLOW.

**Bacteria:** Bacteria are single-celled, living, microscopic organisms which use organic matter for food and produce waste products. The three main types are: aerobic, anaerobic and facultative.

**Base:** A substance that takes up or accepts protons, dissociates in water to produce hydroxyl (OH<sup>-</sup>) ions, reacts with metals and is corrosive.

**Berm:** The earthen dike that surrounds ponds, lagoons and containment areas for hazardous material.

**Biomass:** Amass or clump of living organisms feeding on wastes in wastewater, dead organisms and other debris. The mass may protect the organisms, as well as store food supplies. Also called ZOOGLAAL MASS.

**Blue-Green Algae:** Varieties of algae characterized by their bluish-green color. The appearance of blue-green algae indicates unhealthy conditions in lagoon cells, often associated with organic overloading and lack of adequate dissolved oxygen.

**Cavitation:** The formation and collapse of a gas pocket or bubble on the blade of an impeller or gate of a valve. The collapse of the bubble drives water into the impeller or gate with a terrific force that can cause pitting of the surface. Cavitation is indicated by loud hammering noises.

**Carbon Dioxide:** A common gas, CO<sub>2</sub>, found abundantly in air, is a product of bacterial respiration and used by algae in photosynthesis. The concentration of carbon dioxide in the lagoon water governs the pH of the lagoon.

**Carcinogen:** Any substance that tends to produce cancer in an organism.

**Chloramines:** Compounds formed by the reaction of hypochlorous acid (or aqueous chlorine) with ammonia.

**Chlorination:** The application of chlorine to water for disinfection or oxidation of undesirable compounds. Chlorine compounds are gas and liquid or solid (hypochlorites).

**Chlorinator:** A metering device which is used to add chlorine to water.

**Chlorine Contact Unit:** A baffled basin that provides sufficient time for disinfection to occur.

**Chlorine Demand:** The difference between the amount of chlorine added to water and the amount of chlorine residual remaining after a given contact time.

**Chlorine Residual:** The amount of free chlorine remaining after meeting chlorine demand under given conditions and is necessary to complete disinfection.

**Chlorine Requirement:** The amount of chlorine needed for a particular treatment.

**Chlororganic:** Organic compounds combined with chlorine.

**Clarification:** Any process or processes used to reduce the concentration of suspended matter in a liquid, such as quiescent settling or sedimentation. Lagoons provide clarification across the cells and in quiescent zones in aerated systems, allowing solids to settle into a sludge layer.

---

**Clarifier:** A tank or basin in which the heavier suspended solids settle to the bottom. Clarifiers are also called SETTLING BASINS and SEDIMENTATION BASINS.

**Clean Water Act:** Federal legislation passed in 1972 creating the Environmental Protection Agency, requiring a nationwide system for controlling pollutant discharges and providing for construction and regulation of publicly owned treatment works.

**Coagulation:** The clumping together of very fine particles into larger particles caused by the use of chemicals (coagulants).

**Coliform:** The presence of coliform bacteria indicates that the water is polluted, may contain pathogenic organisms and indicate the possible presence of human or animal waste. Fecal coliform are specific to feces from warm-blooded animals, including humans. The fecal coliform test is a specific coliform test used to regulate and protect public health from WWTP discharges containing pathogens.

**Colloids:** Very small, finely divided particles that do not dissolve for a long time due to their small size and negative electrical charge.

**Combined Sewer:** A sewer designed to carry both sanitary wastewater and storm- or surface-water runoff.

**Comminutor:** A device used to reduce the size of the solid chunks in wastewater influent by shredding. (Also called a Barminutor)

**Composite (Proportional) Sample:** A collection of individual samples obtained at regular intervals during a 24-hour period. Each individual sample is combined with the others in proportion to the rate of flow when the sample was collected. The resulting mixture, or composite, forms a representative sample and is analyzed to determine the average conditions during the sampling period.

**Coning:** Development of a cone-shaped flow of liquid, like a whirlpool, through sludge. This can occur in a sludge hopper during sludge withdrawal when the sludge becomes too thick. Part of the sludge remains in place while the liquid is removed.

**Contamination:** The introduction into water of microorganisms, chemicals, toxic substances, wastes, or wastewater in a concentration that makes the water unfit for its next intended use.

**Conventional Treatment:** The preliminary treatment, sedimentation, flotation, trickling filter, rotating biological contactor, activated sludge and chlorination wastewater treatment processes.

**Crest:** The bottom edge of a weir plate.

**Cross-Connection:** A connection between a drinking water system and an unapproved system.

**Crustaceans:** A class of microscopic water animals that consume large quantities of bacteria and algae.

**Daphnia:** A crustacean commonly found in wastewater lagoons.

**Dechlorination:** The removal of chlorine from the effluent of a treatment plant.

**Denitrification:** An anaerobic process that occurs when nitrite and nitrate ions are reduced to nitrogen gas and bubbles are formed. These bubbles attach to sludge flocs, causing rising sludge that floats to the surface of secondary clarifiers.

**Detention Time:** The theoretical time that water may stay in a lagoon. It is the total volume of the lagoon divided by the flow rate. Usually expressed in days of time.

---

**Disinfection:** The process designed to kill most microorganisms in water, including the destruction or inactivation of pathogenic bacteria. Disinfection differs from sterilization which destroys all living forms.

**Dissolved Oxygen:** Molecular (atmospheric) oxygen dissolved in water or wastewater, usually abbreviated as DO.

**Dissolved Solids:** The salts and other residues left after evaporation of water that has been passed through a laboratory filter. Dissolved solids cannot be filtered out. Some colloidal solids may not be in true solution, but if they pass through the standard membrane filter, they are considered dissolved solids. (See suspended solids)

**Diurnal:** Having a daily cycle; usually a 24-hour period from 12:01am to 12:00pm.

**Duckweed:** A water plant with single small leaf that floats and accumulates on the surface of lagoons.

**Effluent:** The treated water leaving the treatment plant.

**Endogenous Respiration:** A reduced level of respiration in which organisms break down compounds within their own cells to produce the oxygen they need.

**F/M Ratio:** Food to microorganism ratio. A measure of food (organic waste) provided to bacteria in an aeration tank.

**Facultative:** A combination of both aerobic and anaerobic conditions. Facultative cells have both aerobic and anaerobic zones. Facultative bacteria are able to exist in both aerobic and anaerobic conditions. A facultative pond is commonly used to treat wastewater flows in small communities, it has an upper aerobic zone, a lower anaerobic zone, and algae provide most of the oxygen for the bacteria.

**Fermentation:** A process of decomposition of organic solid materials by bacteria and other biological actions.

**Filamentous:** The property of growing in long strings, or filaments. Algae and bacteria have filamentous forms. Algae filaments can clog up equipment and be a nuisance in receiving waters. Bacterial filaments are a common cause of bulking in activated sludge.

**Floc:** Clumps of bacteria and particulate impurities that have come together and formed a cluster.

**Flocculation:** The gathering together of fine particles after coagulation to form larger particles by a process of gentle mixing.

**Free Available Residual Chlorine:** That portion of the total available chlorine residual composed of dissolved chlorine gas ( $Cl_2$ ), hypochlorous acid ( $HOCl$ ), and/or hypochlorite ion ( $OCl^-$ ) remaining in water after chlorination.

**Free Oxygen:** Oxygen can be dissolved in water as the soluble gas  $O_2$  when it is called free oxygen, or it can be available as a combined form in compounds such as nitrates and sulfates.

**Freeboard:** The vertical distance from the normal water surface to the top of the confining wall.

**Grab Sample:** A single sample of water collected at a particular time and place which represents the composition of water only at that time and place.

**Green Algae:** The common forms of algae in an aerobic lagoon environment. Green algae are essential for lagoon treatment.

---

---

**Grit:** Raw sewage carries a variable amount of solids such as sand, and other heavier settleable solids. These are generally classed as grit.

**Hard Water:** Water having a high concentration of calcium and magnesium ions.

**Head:** The vertical distance (in feet) equal to the pressure (in psi) at a specific point. The pressure head is equal to the pressure in psi times 2.31 ft/psi.

**Headworks:** The facilities where wastewater enters a wastewater treatment plant, generally consisting of bar screens, comminutors, a wet well and pumps.

**Hydraulic Loading:** The flow of water per acre of surface area.

**Hydrogen Sulfide:** A very odorous and poisonous gas. Commonly known as rotten egg gas. It is a combined form of hydrogen and sulfur with the formula H<sub>2</sub>S.

**Hydrologic Cycle:** The process of evaporation of water into the air and its return to earth by precipitation. (Also called the WATER CYCLE)

**Hypochlorinators:** Chlorine pumps, chemical feed pumps or devices used to dispense chlorine solutions made from hypochlorites into the water being treated.

**Infiltration:** The gradual flow of water into the soil.

**Inflow:** Water discharged into the sewer system from sources other than regular connections, including yard drains, foundation drains and around manhole covers.

**Influent:** The flow coming into the system.

**Inorganic:** Material such as sand, salt, iron, calcium salts and other mineral materials and other than of plant or animal origin or of carbon compounds (ORGANIC).

**Methane:** A combustible gas produced during anaerobic fermentation of organic matter, such as by anaerobic digestion of wastewater solids.

**Microorganisms:** Microscopic living organisms.

**Milligrams Per Liter, Mg/L:** A measure of the concentration by weight of a substance per unit volume. One thousandth of a gram in one liter. One mg/L is equal to one part per million (ppm).

**MPDES Permit:** Montana Pollutant Discharge Elimination System permit. This permit lists the conditions that must be met before treatment plants can discharge an effluent into state receiving waters.

**Nitrification:** An aerobic process in which bacteria change ammonia and organic nitrogen into nitrite and nitrate forms of nitrogen.

**Nonpotable:** Water that is considered unsafe and/or unpalatable for drinking.

**Nonpoint Discharge:** A source of wastewater that comes from a relatively large area and would have to be controlled by a management or conservation practice. Storm waters and most agricultural waters are nonpoint sources.

**NPDES:** National Pollutant Discharge Elimination System. Establishes national levels of treatment and conditions for discharges to receiving waters. (See MPDES)

**Nutrients:** Substances required by living plants and organisms. Forms of nitrogen and phosphorous are nutrients that can cause problems in receiving waters.

---

**Organic:** Substances from animal or plant sources. Organic substances contain carbon. (See INORGANIC)

**Organic Acids:** Weak acids formed from organic compounds, such as acetic acid and citric acid. These acids form first in anaerobic digesters and then are converted to methane. The organic acids in wastewater lagoons are much more complex and generally weaker.

**Oxidation Pond:** A term often used interchangeably with lagoon. Oxidation ponds are used after other treatment processes.

**Ozonation:** The application of ozone to water primarily for disinfection.

**pH:** (Pronounce letters separately.) The intensity of the basic or acid condition of a liquid.

**Palmer-Bowlus Flume:** A flow measuring device consisting of a preformed flume.

**Parshall Flume:** A flow measuring device consisting of a preformed flume with restrictive area called the throat. The head of water at a stilling well just upstream from the narrow part of the throat is measured and a chart is used to obtain flow rate.

**Pathogenic Organisms:** Organisms capable of causing diseases in a host.

**Percolation:** The movement or flow of water through soil or rocks. A discharge option for many wastewater treatment systems. In Montana, a Montana Ground Water Pollutant Discharge Elimination System (MGWPES) permit and sampling in groundwater monitoring wells are required.

**Photosynthesis:** A complex process in all green plants that contain chlorophyll. The process uses sunlight as energy to convert carbon dioxide into plant growth. As a by-product oxygen is released.

**Polishing Pond:** A final lagoon cell after other treatment which completes the treatment, or "polishes" the effluent.

**Population Equivalent:** An average BOD contribution by each person to a domestic sewage. The accepted population equivalent is 0.17 pounds of BOD per person per day.

**Potable Water:** Water that is considered satisfactory for drinking.

**PPM:** Abbreviation for Parts Per Million. See MILLIGRAMS PER LITER (mg/L)

**Prechlorination:** The addition of chlorine in the collection system or at the headworks of the plant prior to treatment.

**Primary Cell:** The first cell in a series.

**Primary Treatment:** A physical process that takes place in a basin to allow substances that readily settle or float to be separated from the wastewater.

**Rip-Rap:** Erosion control by placement of large rocks along an embankment.

**Rotifer:** A form of microscopic animal that feeds on algae and bacteria. The free-swimming protozoa are common in lagoons. Rotifers require aerobic conditions.

**Saturation:** Oxygen saturation is the concentration of free dissolved oxygen in water that is in equilibrium with atmospheric oxygen. It is measured in milligrams per liter (mg/l). It varies with both temperature and atmospheric pressure.

**Secondary:** The second in a series of cells.

---

**Secondary Treatment:** A wastewater treatment process used to convert dissolved or suspended materials into a form more readily separated from wastewater. Usually follows primary sedimentation treatment and uses biological processes to convert wastes to solids that settle in secondary clarifiers. Also occurs in lagoon systems.

**Sedimentation:** A process in which solid particles settle out of water.

**Septic:** A condition that exists when there is no dissolved oxygen (see anaerobic). Anaerobic bacteria and other microorganisms continue to use parts of the waste for food but produce foul odors and black colored water. The waste in the common septic tank is typical of this condition.

**Short-Circuiting:** A hydraulic condition in which water may find a short path between the inlet and outlet of a cell with subsequent shortened time of retention.

**Sludge:** The settleable solids separated from wastewater during treatment.

**Stabilization:** The conversion of biodegradable materials into more stable solids. Stabilization is the primary function of wastewater lagoons and treatment plants. Lagoons are often called stabilization ponds.

**Stratification:** The formation of indistinct layers of slightly variable density of waters. Often caused by warming of the surface with an absence of mixing.

**Surface Loading:** Lagoon loading is rated organically in pounds of BOD per acre of surface area per day. Northern climates require lower loading rates than warmer areas, because cold weather slows down the stabilization processes of microorganisms. Treatment plants clarifiers are rated hydraulically in flow (gpd) per surface area (sq ft).

**Suspended Solids:** Solid material so finely divided or light in weight that it does not settle but can be filtered in a lab test and weighed. Also referred to as Total Suspended Solids (TSS).

**TSS:** Abbreviation for TOTAL SUSPENDED SOLIDS, a test measuring the amount of filterable solids in wastewater.

**Tertiary Treatment:** Process that upgrades treatment of wastewater effluent to meet specific reuse and discharge requirements. (ADVANCED TREATMENT)

**Toxic:** A substance that is poisonous to an organism.

**Turbidity:** The cloudy appearance of water caused by the presence of suspended and colloidal matter. A turbidity measurement is used to indicate the clarity of water.

**UV:** Ultraviolet light. UV is useful as a method of disinfection. It leaves no residual and is often used where no chlorine residual (or a very low residual) is allowed to be discharged.

**Water Quality Act:** Montana's primary water pollution control legislation that parallels the federal Clean Water Act. It establishes the public policy for Montana to: 1) conserve water resources by protecting, maintaining and improving water quality for all its beneficial uses, and 2) provides a comprehensive program for the prevention, abatement and control of water pollution.

**Weir:** (1) A wall or plate placed in an open channel and used to measure the flow of water. The depth of the flow over the weir can be used to calculate the flow rate, or a chart or conversion table may be used. (2) A wall or obstruction used to control flow (from settling tanks and clarifiers) to assure uniform flow rate and avoid short-circuiting.

## National Pollutant Discharge Elimination System (NPDES)

PERMITTEE NAME/ADDRESS (including facility name/location if different)	<b>Discharge Monitoring Report (DMR)</b> (2-16) (17-19)		Note: Read instructions before completing this form.
Name	<b>PERMIT NUMBER</b>	<b>DISCHARGE NUMBER</b>	
Address			
Facility	<b>MONITORING PERIOD</b>		
Location	FROM	TO	
	(20-21) (22-23) (24-25)	(26-27) (28-29) (30-31)	

PARAMETER (32-37)		(3 Card Only) QUANTITY OR LOADING (46-53) (54-61)			(4 Card Only) QUANTITY OR CONCENTRATION (38-45) (46-53) (54-61)			NO EX (62-63)	FREQUENCY OF ANALYSIS (64-68)	SAMPLE TYPE (69-70)
		AVERAGE	MAXIMUM	UNITS	MINIMUM	AVERAGE	MAXIMUM			
	SAMPLE MEASUREMENT									
	PERMIT REQUIREMENT									
	SAMPLE MEASUREMENT									
	PERMIT REQUIREMENT									
	SAMPLE MEASUREMENT									
	PERMIT REQUIREMENT									
	SAMPLE MEASUREMENT									
	PERMIT REQUIREMENT									

<b>NAME/TITLE PRINCIPAL EXECUTIVE OFFICER</b>	I CERTIFY UNDER PENALTY OF LAW THAT I HAVE PERSONALLY EXAMINED AND AM FAMILIAR WITH THE INFORMATION SUBMITTED HEREIN; AND BASED ON MY INQUIRY OF THOSE INDIVIDUALS IMMEDIATELY RESPONSIBLE FOR OBTAINING THE INFORMATION, I BELIEVE THE SUBMITTED INFORMATION IS TRUE, ACCURATE, AND COMPLETE. I AM AWARE THAT THERE ARE SIGNIFICANT PENALTIES FOR SUBMITTING FALSE INFORMATION, INCLUDING THE POSSIBILITY OF FINE AND IMPRISONMENT. SEE 18 U.S.C. & 101 AND 33 U.S.C. 1319 (Penalties under those statues may include fines up to \$10,000 and or maximum imprisonment of between 6 months and 6 years)		TELEPHONE		DATE		
<b>TYPED OR PRINTED</b>		SIGNATURE OF PRINCIPAL EXECUTIVE OFFICER OR AUTHORIZED AGENT	AREA CODE	NUMBER	YEAR	MO	DAY

COMMENTS AND EXPLANATION OF ANY VIOLATIONS (Reference all attachments here)







# HARLEM WASTEWATER TREATMENT FACILITY

## BOD TREND CHART

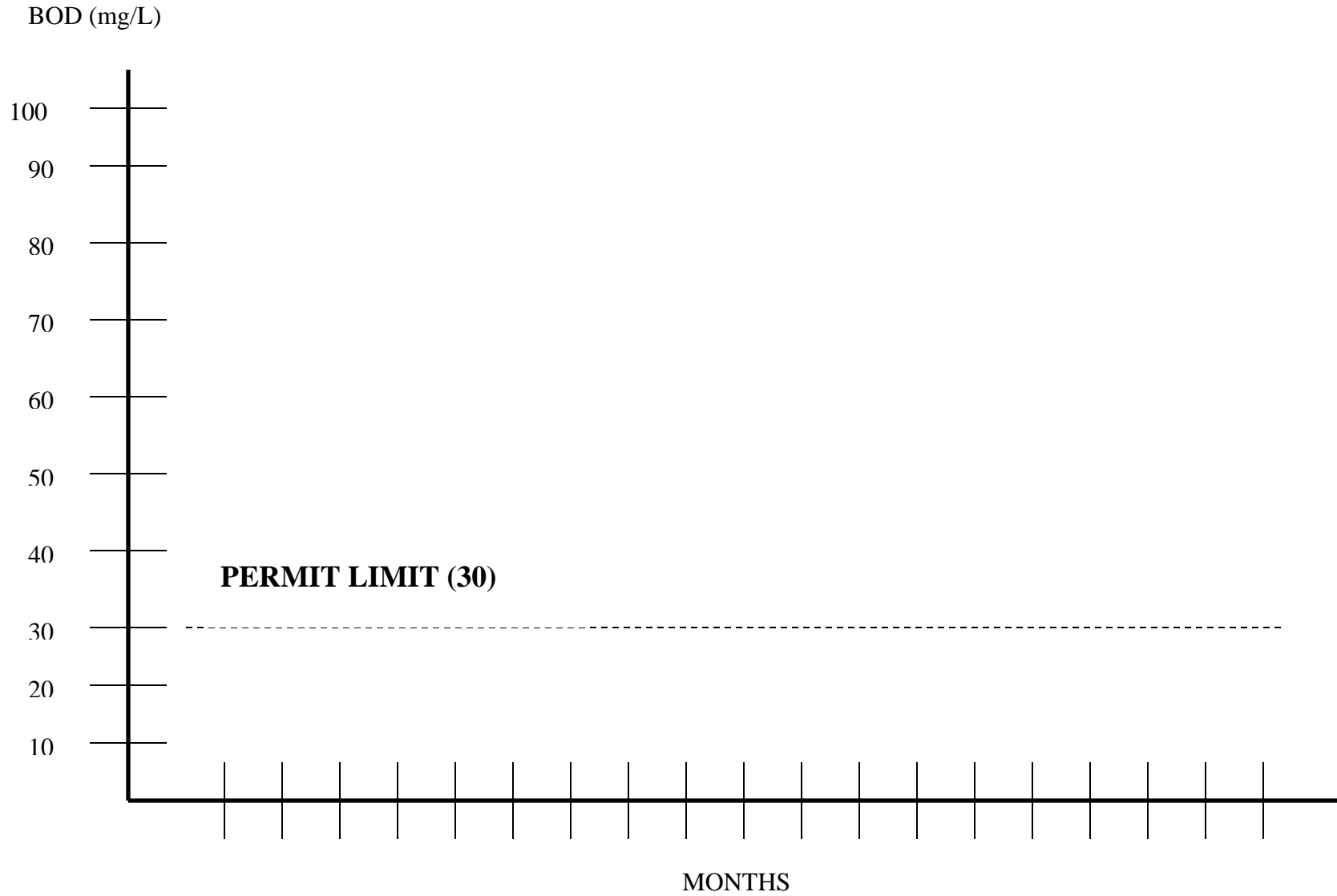

**(Name of Facility) WASTEWATER TREATMENT FACILITY**

**TSS TRENDCHART**

